

CURRENT OWNER		TOPO	UTILITIES	STRT / ROAD	LOCATION	CURRENT ASSESSMENT				801 FY2025 BARNSTABLE, MA VISION						
DENTREMONT, LEANN KENNEDY TR 50 NORTHGATE ROAD TEWKSBURY MA 01876						Description	Code	Assessed	Assessed							
						RESIDNTL	1010	284,400	284,400							
					4	RES LAND	1010	178,500	178,500							
SUPPLEMENTAL DATA						Total		462,900	462,900							
Alt Prcl ID		Split Zonin		Plan Ref. 96/137												
#DL 1 LOT 18		#DL 2		Land Ct#												
GIS ID F_984760_2695851		Assoc Pid#														
RECORD OF OWNERSHIP		BK-VOL/PAGE	SALE DATE	Q/U	V/I	SALE PRIC	VC	PREVIOUS ASSESSMENTS (HISTORY)								
DENTREMONT, LEANN KENNEDY TR		18474 0104	04-20-2004	U	I	1	1F	Year	Code	Assessed	Year	Code	Assessed			
DENTREMONT, LEANN KENNEDY TR		18323 0240	03-16-2004	U	I	1	1A	2025	1010	284,400	2024	1010	282,100			
KENNEDY, ROBERT L & NANCY		5358 0239	10-15-1986	U	I	1	1A		1010	178,500	2023	1010	241,000			
ANDREWS, MARY J		P0671E1 0	07-15-1985	U	I	1	1A					1010	176,400			
ANDREWS, DAVID B & MARY J		0792 0275	09-11-1951	U		0		Total		462,900	Total		460,600			
								Total		462,900	Total		417,400			
EXEMPTIONS			OTHER ASSESSMENTS				This signature acknowledges a visit by a Data Collector or Assessor									
Year	Code	Description	Amount	Code	Description	Number	Amount	Comm	Int							
Total		0.00								APPRAISED VALUE SUMMARY						
										Appraised Bldg. Value (Card) 261,100						
										Appraised Xf (B) Value (Bldg) 21,100						
										Appraised Ob (B) Value (Bldg) 2,200						
										Appraised Land Value (Bldg) 178,500						
										Special Land Value 0						
										Total Appraised Parcel Value 462,900						
										Valuation Method C						
										Total Appraised Parcel Value 462,900						
BUILDING PERMIT RECORD						VISIT / CHANGE HISTORY										
Permit Id	Issue Date	Type	Description	Amount	Insp Date	% Comp	Date Comp	Comments	Date	Id	Type	Is	Cd	Purpost/Result		
									05-26-2020	WD			FR	Field Review		
									10-06-2017	SR	02		03	Cycl Insp Comp		
									03-20-2006	DR	22		22	Change of Address		
									01-18-2002	PT	02		02	Bldg Permit Completed		
									10-15-1988	ME	02		01	Meas/Est		
LAND LINE VALUATION SECTION																
B	Use Code	Description	Zone	LA	Land Units	Unit Price	Size Adj	AC Disc	Site Index	Cond.	Nbhd.	Nbhd. Adj	Notes	Location Adjustmen	Adj Unit P	Land Value
1	1010	Single Fam M-0	RB	4	0.440 AC	176,344.00	2.00014	1.0000	5	1.00	0106	1.150		1.0000	405,626.4	178,500
Total Card Land Units					0.44	AC	Parcel Total Land Area					0.44	Total Land Value			178,500

CONSTRUCTION DETAIL			CONSTRUCTION DETAIL (CONTINUED)		
Element	Cd	Description	Element	Cd	Description
Style	01	Ranch			
Model	01	Residential			
Grade:	C	Average			
Stories	1	1 Story			
Exterior Wall 1	14	Wood Shingle			
Exterior Wall 2					
RooF Structure	03	Gable/Hip			
RooF Cover	03	Asph/F Gls/Cmp			
Interior Wall 1	05	Drywall			
Interior Wall 2					
Interior Floor 1	14	Carpet			
Interior Floor 2	12	Hardwood			
Heat Fuel	02	Oil			
Heat Type	05	Hot Water			
AC Type	01	None			
Bedrooms	02	2 Bedrooms			
Full Baths	2				
Half Baths	0				
Extra Fixtures					
Total Rooms	5	5 Rooms			
Bath Style					
Kitchen Style					
Occupancy					
Sewer Occupan					
Accessory Apt					
Foundation Alt	02	Conc. Block			
Rms Prts					
Bath Split	20	2 Full-0 Half			
			CONDO DATA		
			Parcel Id	C	Owne 0.0
				B	S
			Adjust Type	Code	Description
			Condo Flr		Factor%
			Condo Unit		
			COST / MARKET VALUATION		
			Building Value New		378,478
			Year Built		1949
			Effective Year Built		1984
			Depreciation Code		A
			Remodel Rating		
			Year Remodeled		
			Depreciation %		31
			Functional Obsol		0
			External Obsol		0
			Trend Factor		1
			Condition		
			Condition %		
			Percent Good		69
			RCNLD		261,100
			Dep % Ovr		
			Dep Ovr Comment		
			Misc Imp Ovr		
			Misc Imp Ovr Comment		
			Cost to Cure Ovr		
			Cost to Cure Ovr Comment		

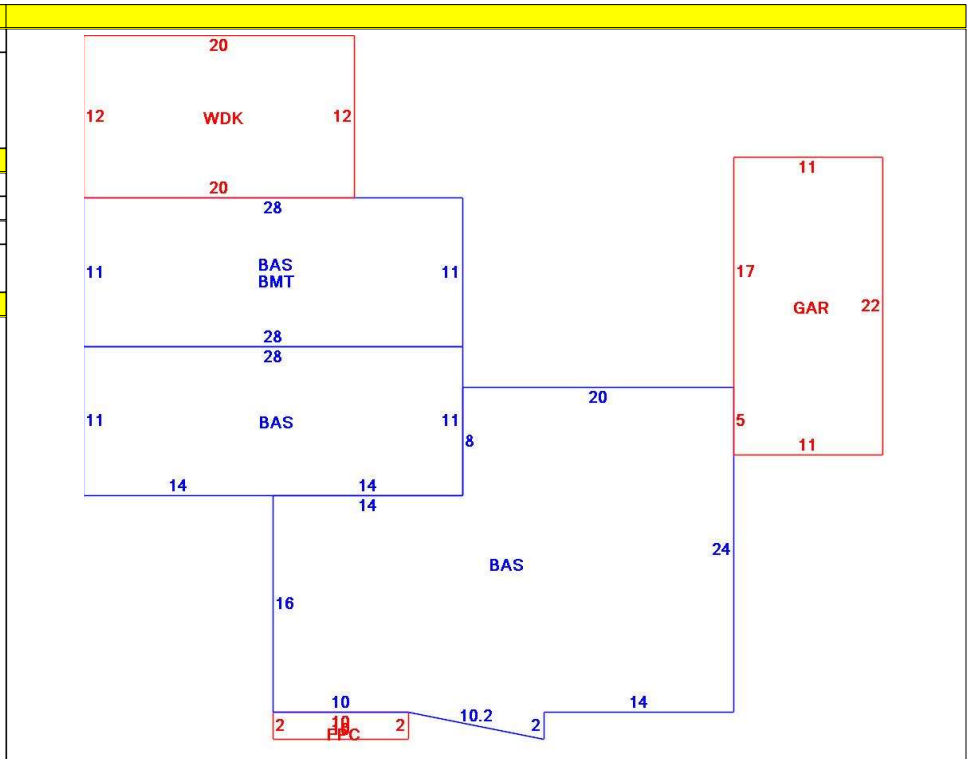

OB - OUTBUILDING & YARD ITEMS(L) / XF - BUILDING EXTRA FEATURES(B)										
Code	Description	L/B	Units	Unit Price	Yr Blt	Cond. Cd	% Gd	Grade	Grade Adj.	Appr. Value
FPL1	Fireplace 1 sto	B	1	5000.00	1982		69		0.00	3,500
WDC	Wood Decking	L	240	20.00	1990		42		0.00	2,200
GAR	Attached Gara	B	242	40.00	1982		69		0.00	7,900
BMT	Basement-Unfi	B	308	26.01	1982		69		0.00	8,700
FOPC	Open Prch-roo	B	20	55.00	1982		69		0.00	1,000

BUILDING SUB-AREA SUMMARY SECTION						
Code	Description	Living Area	Floor Area	Eff Area	Unit Cost	Undeprec Value
BAS	First Floor	1,330	1,330	1,330	284.57	378,478
BMT	Basement Area	0	308	0	0.00	0
FPC	Open Porch Conc. Floor	0	20	0	0.00	0
GAR	Attached Garage	0	242	0	0.00	0
WDC	Wood Deck	0	240	0	0.00	0
Ttl Gross Liv / Lease Area		1,330	2,140	1,330		378,478

