

CURRENT OWNER		TOPO	UTILITIES	STRT / ROAD	LOCATION	CURRENT ASSESSMENT						801 FY2025 BARNSTABLE, MA VISION						
SAMANT, NINAD N & JOANNE M TRS NINAD N & JOANNE M SAMANT LIVI 29 CAMELOT DRIVE SHREWSBURY MA 01545					4 Hyannis CU	Description	Code	Assessed	Assessed									
						RESIDNTL	1020	592,900	592,900									
						SUPPLEMENTAL DATA								Total			592,900	592,900
Alt Prcl ID		Split Zonin RB;RF-1		Plan Ref. Land Ct# 20984-B-1		#SR		Life Estate PP STATU A:Active										
#DL 1 UNIT 16		#DL 2		GIS ID F_985112_2695172		Assoc Pid#												
RECORD OF OWNERSHIP				BK-VOL/PAGE	SALE DATE	Q/U	V/I	SALE PRICE	VC	PREVIOUS ASSESSMENTS (HISTORY)								
SAMANT, NINAD N & JOANNE M TRS				C97-1 0	09-09-2024	U	I	100	1F	Year	Code	Assessed	Year	Code	Assessed V	Year	Code	Assessed
SAMANT, NINAD & JOANNE				C97-1 0	07-25-2019	U	I	426,000	1	2025	1020	592,900	2024	1020	562,300	2023	1020	547,700
NORDSTROM, KAY F				C97-1 0	10-25-2013	Q	I	287,500	00									
CARDILLO, VINCENT				C97-1 0	06-30-1999	Q	I	128,000	00									
GUTKOWSKI, THADDEUS & PUGLIESE				C97-1 0	02-15-1986	U	I	1	A									
Total										592,900		Total		562,300		Total		547,700
EXEMPTIONS				OTHER ASSESSMENTS				This signature acknowledges a visit by a Data Collector or Assessor										
Year	Code	Description		Amount	Code	Description	Number	Amount	Comm Int									
Total				0.00														
ASSESSING NEIGHBORHOOD										APPRAISED VALUE SUMMARY								
Nbhd		Nbhd Name		B		Tracing		Batch		Appraised Bldg. Value (Card)						581,800		
0001								HYAN		Appraised Xf (B) Value (Bldg)						4,300		
										Appraised Ob (B) Value (Bldg)						6,800		
										Appraised Land Value (Bldg)						0		
										Special Land Value						0		
										Total Appraised Parcel Value						592,900		
										Valuation Method						C		
										Total Appraised Parcel Value						592,900		
BUILDING PERMIT RECORD										VISIT / CHANGE HISTORY								
Permit Id	Issue Date	Type	Description	Amount	Insp Date	% Comp	Date Comp	Comments		Date	Id	Type	Is	Cd	Purpost/Result			
EXPR-24-3 19-264	04-03-2024 01-25-2019	835 822	Sid/Wind/Roof/ Insulation	23,600 1,600	06-30-2019	100 100	06-30-2019	RE-SHINGLE ROOF weatherization		05-25-2023 05-26-2020 03-02-2020 01-24-2020 03-21-2019 03-23-2015 03-12-2013	TR WD SAF CK SR TP TP	03 03 02 03 03		16 FR 20 16 03 16 15	In Office Review Field Review Sale Review In Office Review Cycl Insp Comp In Office Review Abatement Review			
LAND LINE VALUATION SECTION																		
B	Use Code	Description	Zone	Dist	Land Type	Land Units	Unit Price	Size Adj	Site Index	Cond.	Nbhd.	Nbhd. Adj	Notes		Location Adjustmen	Adj Unit P	Land Value	
1	102U	Condominium M	SPLI	4	Hyannis	0 SF	0.00	1.00000	5	1.00	0001	1.000			0.0000	0	0	
Total Card Land Units						0 SF	Parcel Total Land Area						0.00	Total Land Value				0

CONSTRUCTION DETAIL			CONSTRUCTION DETAIL (CONTINUED)		
Element	Cd	Description	Element	Cd	Description
Style	55	Condominium			
Model	05	Res Condo			
Grade	C	Average			
Stories	1	1 Story			
Occupancy	0				
Interior Wall 1	05	Drywall			
Interior Wall 2					
Interior Floor 1	09	Pine/Soft Wood			
Interior Floor 2					
Heat Fuel	03	Gas			
Heat Type	04	Hot Air			
AC Type	03	Central			
Bedrooms	02	2 Bedrooms			
Full Baths	1	1 Full			
Half Baths	0				
Extra Fixtures					
Total Rooms	4	4 Rooms			
Bath Style					
Kitchen Style					
Master Deed L					
Bath Split	809	1 Full-0 Half			
Foundation	10	Conc. Block			
AC Type Alt	02				
Sewer Occupan					
CONDO DATA					
Parcel Id	104271	C 0570	Owne	4.7	
	HARBOR VILLAGE	B 1	S 1		
Adjust Type	Code	Description	Factor%		
Condo Flr			100		
Condo Unit	MKT0	MKT0	100		
COST / MARKET VALUATION					
Building Value New		684,486			
Year Built		1955			
Effective Year Built		2005			
Depreciation Code		VG			
Remodel Rating					
Year Remodeled					
Depreciation %		15			
Functional Obsol		0			
External Obsol		0			
Trend Factor		1			
Condition					
Condition %					
Percent Good		85			
Cns Sect Rcnd		581,800			
Dep % Ovr					
Dep Ovr Comment					
Misc Imp Ovr					
Misc Imp Ovr Comment					
Cost to Cure Ovr					
Cost to Cure Ovr Comment					

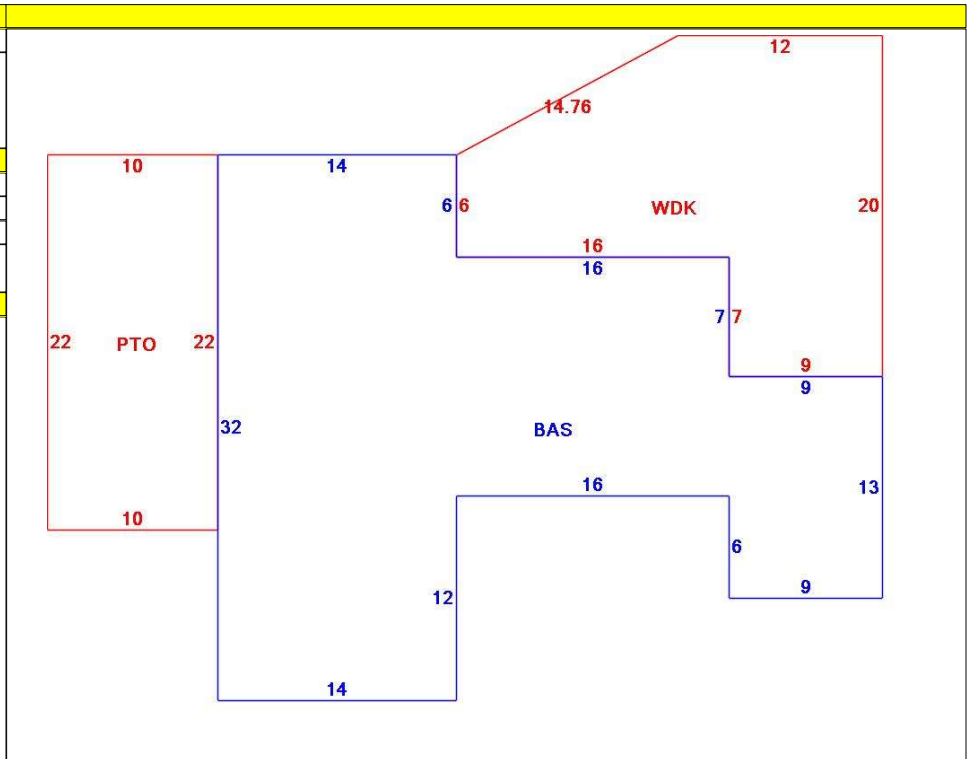

OB - OUTBUILDING & YARD ITEMS(L) / XF - BUILDING EXTRA FEATURES(B)

Code	Description	L/B	Units	Unit Price	Yr Blt	Cond. Cd	% Gd	Grade	Grade Adj.	Appr. Value
FPL1	Fireplace 1 sto	B	1	5000.00	2002		85		0.00	4,300
WDC	Wood Decking	L	342	20.00	2010		72		0.00	4,800
PAT2	Patio-Good	L	220	9.94	2010		86		0.00	2,000

BUILDING SUB-AREA SUMMARY SECTION

Code	Description	Living Area	Floor Area	Eff Area	Unit Cost	Undeprec Value
BAS	First Floor	789	789	789	867.54	684,486
PTO	Patio	0	220	0	0.00	0
WDK	Wood Deck	0	343	0	0.00	0
Ttl Gross Liv / Lease Area		789	1,352	789		684,486

