

CURRENT OWNER		TOPO	UTILITIES	STRT / ROAD	LOCATION	CURRENT ASSESSMENT				
DAVIS, JANE M TR JANE M DAVIS REVOCABLE TRUST 304 BROOKSBY VILLAGE DRIVE UNIT 403 PEABODY MA 01960					4 Hyannis CU	Description	Code	Assessed	Assessed	801 FY2025 BARNSTABLE, MA VISION
						RESIDNTL	1020	588,900	588,900	
SUPPLEMENTAL DATA										
Alt Prcl ID			Split Zonin RB;RF-1		Plan Ref.					
BID Parcel			ResExpt Q		Land Ct#	20984-B-1				
#DL 1			UNIT 19		#SR					
#DL 2					Life Estate					
GIS ID			F_985112_2695172		PP STATU	VIEW PARCEL T				
					Assoc Pid#					
						Total		588,900	588,900	

RECORD OF OWNERSHIP		BK-VOL/PAGE	SALE DATE	Q/U	V/I	SALE PRICE	VC	PREVIOUS ASSESSMENTS (HISTORY)						
DAVIS, JANE M TR		C97-1	0	04-14-2016	Q	I	440,000	00	Year	Code	Assessed	Year	Code	Assessed
HORN, RICHARD W & DIANA G		C97-1	0	05-20-2005	Q	I	450,000	00	2025	1020	588,900	2024	1020	551,600
CONATHAN, BARBARA A		C97-1	0	03-24-2003	Q	I	340,000	00						
BABCOCK, CHRISTOPHER H		C97-1	0	01-15-1989	Q	I	181,000	U						
FRENCH, LLOYD S & JOYCE G		C97-1	0	04-15-1984	Q	I	113,000	U						
						Total		588,900	Total		551,600	Total		545,800

EXEMPTIONS			OTHER ASSESSMENTS					
Year	Code	Description	Amount	Code	Description	Number	Amount	Comm Int
Total			0.00					

ASSESSING NEIGHBORHOOD				
Nbhd	Nbhd Name	B	Tracing	Batch
0001				HYAN

NOTES									
This signature acknowledges a visit by a Data Collector or Assessor									
APPRAISED VALUE SUMMARY									
Appraised Bldg. Value (Card)								579,200	
Appraised Xf (B) Value (Bldg)								7,400	
Appraised Ob (B) Value (Bldg)								2,300	
Appraised Land Value (Bldg)								0	
Special Land Value								0	
Total Appraised Parcel Value								588,900	
Valuation Method								C	
Total Appraised Parcel Value								588,900	

BUILDING PERMIT RECORD								VISIT / CHANGE HISTORY						
Permit Id	Issue Date	Type	Description	Amount	Insp Date	% Comp	Date Comp	Comments	Date	Id	Type	Is	Cd	Purpost/Result
19-3390	10-31-2019	835	Sid/Wind/Roof/	10,000		100		Siding, Window replacement (05-25-2023	TR	03		16	In Office Review
B35480	10-01-1992	NR	New Roof	4,000	01-15-1993	100	12-31-1993	HP RE-ROO	04-24-2023	AG	22		22	Change of Address
									05-26-2020	WD			FR	Field Review
									03-21-2019	SR	02		03	Cycl Insp Comp
									09-29-2017	TR	03		16	In Office Review
									03-24-2015	TP	03		16	In Office Review

LAND LINE VALUATION SECTION																		
B	Use Code	Description	Zone	Dist	Land Type	Land Units	Unit Price	Size Adj	Site Index	Cond.	Nbhd.	Nbhd. Adj	Notes	Location Adjustmen	Adj Unit P	Land Value		
1	102U	Condominium M	SPLI	4	Hyannis	0 SF	0.00	1.00000	5	1.00	0001	1.000			0.0000	0	0	
Total Card Land Units						0	SF	Parcel Total Land Area						0.00	Total Land Value			0

CONSTRUCTION DETAIL			CONSTRUCTION DETAIL (CONTINUED)		
Element	Cd	Description	Element	Cd	Description
Style	55	Condominium			
Model	05	Res Condo			
Grade	C	Average			
Stories	1	1 Story			
Occupancy	0				
Interior Wall 1	04	Plywood Panel			
Interior Wall 2					
Interior Floor 1	09	Pine/Soft Wood			
Interior Floor 2					
Heat Fuel	03	Gas			
Heat Type	04	Hot Air			
AC Type	03	Central			
Bedrooms	02	2 Bedrooms			
Full Baths	1	1 Full			
Half Baths	1				
Extra Fixtures					
Total Rooms	4	4 Rooms			
Bath Style					
Kitchen Style					
Master Deed L	809				
Bath Split	11	1 Full-1 Half			
Foundation	02	Conc. Block			
AC Type Alt					
Sewer Occupan					
CONDO DATA					
Parcel Id	104271	C 0570	Ownr	4.7	
	HARBOR VILLAGE	B 1	S 1		
Adjust Type	Code	Description	Factor%		
Condo Flr			100		
Condo Unit	MKT0	MKT0	100		
COST / MARKET VALUATION					
Building Value New		706,284			
Year Built		1957			
Effective Year Built		2001			
Depreciation Code		G			
Remodel Rating					
Year Remodeled					
Depreciation %		18			
Functional Obsol		0			
External Obsol		0			
Trend Factor		1			
Condition					
Condition %					
Percent Good		82			
Cns Sect Rcnld		579,200			
Dep % Ovr					
Dep Ovr Comment					
Misc Imp Ovr					
Misc Imp Ovr Comment					
Cost to Cure Ovr					
Cost to Cure Ovr Comment					

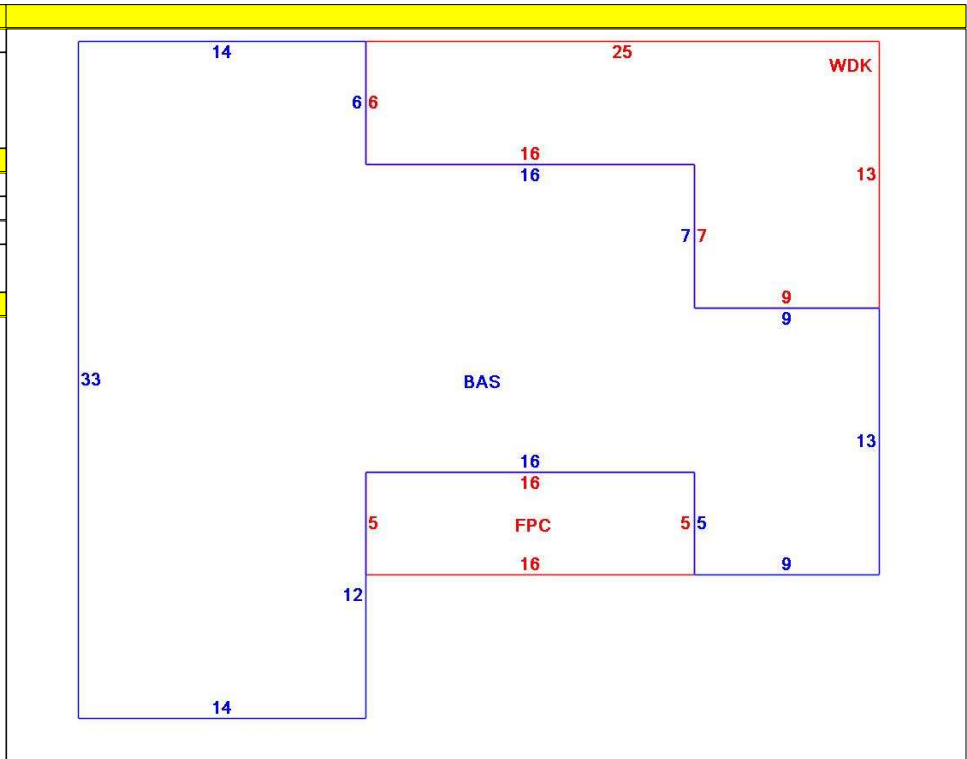

OB - OUTBUILDING & YARD ITEMS(L) / XF - BUILDING EXTRA FEATURES(B)

Code	Description	L/B	Units	Unit Price	Yr Blt	Cond. Cd	% Gd	Grade	Grade Adj.	Appr. Value
FPL1	Fireplace 1 sto	B	1	5000.00	1998		82		0.00	4,100
WDC	Wood Deck w/	L	213	18.00	2000		52		0.00	2,300
FOPC	Open Prch-roo	B	80	55.00	1998		82		0.00	3,300

BUILDING SUB-AREA SUMMARY SECTION

Code	Description	Living Area	Floor Area	Eff Area	Unit Cost	Undeprec Value
BAS	First Floor	819	819	819	862.37	706,284
FPC	Open Porch Conc. Floor	0	80	0	0.00	0
WDC	Wood Deck	0	213	0	0.00	0
Ttl Gross Liv / Lease Area		819	1,112	819		706,284

