

CURRENT OWNER		TOPO	UTILITIES	STRT / ROAD	LOCATION	CURRENT ASSESSMENT				
PUTNAM, WILLIAM B JR TR WILLIAM B PUTNAM JR TRUST 288 SCUDDER AVENUE						Description	Code	Assessed	Assessed	801 FY2025 BARNSTABLE, MA
HYANNIS MA 02601						RESIDENTI RES LAND	1259 1259	1,004,500 200,000	1,004,500 200,000	
SUPPLEMENTAL DATA										
Alt Prcl ID Split Zonin BID Parcel ResExpt Q YES: #DL 1 LOT 9 #DL 2 GIS ID F_983199_2696503				Plan Ref. Land Ct# 36483-D #SR Life Estate PP STATU Assoc Pid#		Total 1,204,500 1,204,500				

VISION

RECORD OF OWNERSHIP		BK-VOL/PAGE	SALE DATE	Q/U	V/I	SALE PRIC	VC	PREVIOUS ASSESSMENTS (HISTORY)									
PUTNAM, WILLIAM B JR TR		C235745	0	04-25-2024	U	I	1	1F	Year	Code	Assessed	Year	Code	Assessed	Year	Code	Assessed
PUTMAN, WILLIAM B JR		C114955	0	07-15-1988	Q	I	650,000	U	2025	1259	1,004,500	2024	1259	1,004,500	2023	1259	924,200
HOFMANN, RICHARD		C105851	0	04-15-1986	Q	I	225,000	U		1259	200,000		1259	200,000		1259	200,000
NICKULAS, LARRY		C97479	0	07-15-1984	Q	V	1	U									
NICKULAS, LARRY		C97479	0	07-15-1984	U	V	1	R									
Total									1,204,500		Total		1,204,500		Total		1,124,200

EXEMPTIONS				OTHER ASSESSMENTS				This signature acknowledges a visit by a Data Collector or Assessor										
Year	Code	Description	Amount	Code	Description	Number	Amount	Comm Int										
2022	5C	RESIDENTIAL EXEMPTION	0.00															
Total			0.00															

ASSESSING NEIGHBORHOOD				APPRAISED VALUE SUMMARY													
Nbhd	Nbhd Name		B	Tracing		Batch											
0109						HYAN											
NOTES																	
SIMMONS HOMESTEAD INN																	
								Appraised Bldg. Value (Card)								802,300	
								Appraised Xf (B) Value (Bldg)								52,800	
								Appraised Ob (B) Value (Bldg)								149,400	
								Appraised Land Value (Bldg)								200,000	
								Special Land Value								0	
								Total Appraised Parcel Value								1,204,500	
								Valuation Method								I	
								Total Appraised Parcel Value								1,204,500	

BUILDING PERMIT RECORD										VISIT / CHANGE HISTORY									
Permit Id	Issue Date	Type	Description	Amount	Insp Date	% Comp	Date Comp	Comments		Date	Id	Type	Is	Cd	Purpost/Result				
EXPR-24-1	09-18-2024	835		9,300		0		Remove and replace one layer		03-11-2022	AS	03		16	In Office Review				
BLDR-24-10	09-04-2024	839		45,000		0		solar panels on the main hous		01-26-2022	LH	03		22	Change of Address				
EXPR-21-1	12-15-2021	835	Sid/Wind/Roof/	5,000		100		Roof		01-21-2022	AS	03		16	In Office Review				
90651	03-06-2006	WD	Wood Deck	4,002	09-24-2007	100	06-30-2007	#90632		05-26-2020	WD			FR	Field Review				
77338	06-16-2004	TP	Temporary	1,000	08-03-2004	100	01-01-2005			08-27-2018	EO	03		16	In Office Review				
56570	10-19-2001	AD	Addition	68,000	01-01-2002	100		ADD TO CAR SHED		05-06-2016	JR	01		03	Cycl Insp Comp				
51728	02-14-2001	OB	Out Building	3,500	01-01-2002	100		CAR SHED		09-24-2007	PT	02		01	Meas/Est				

LAND LINE VALUATION SECTION																		
B	Use Code	Description	Zone	LA	Land Units	Unit Price	Size Adj	AC Disc	Site Index	Cond.	Nbhd.	Nbhd. Adj	Notes		Location Adjustmen	Adj Unit P	Land Value	
1	1259	B&B	RB	4	10	20,000.00	1.00000	1.0000	0	1.00		1.000	10 UNITS			1.0000	20,000	
1	1259	B&B	RB	4	1.100	0.00	1.00000	1.0000	0	1.00		1.000	ACTUAL LOT SIZE			0.0000	0	
Total Card Land Units					1.10	BL	Parcel Total Land Area					1.10	Total Land Value					200,000

CONSTRUCTION DETAIL			CONSTRUCTION DETAIL (CONTINUED)		
Element	Cd	Description	Element	Cd	Description
Style	92	Inn/B+B			
Model	01	Residential			
Grade:	B-	Custom Minus			
Stories	2	2 Stories			
Exterior Wall 1	11	Clapboard			
Exterior Wall 2	14	Wood Shingle			
Roof Structure	03	Gable/Hip			
Roof Cover	03	Asph/F Gls/Cmp			
Interior Wall 1	03	Plastered			
Interior Wall 2	05	Drywall			
Interior Floor 1	09	Pine/Soft Wood			
Interior Floor 2					
Heat Fuel	03	Gas			
Heat Type	05	Hot Water			
AC Type	01	None			
Bedrooms	10	10 Bedrooms			
Full Baths	10				
Half Baths	0				
Extra Fixtures					
Total Rooms	13				
Bath Style					
Kitchen Style					
Occupancy					
Sewer Occupan					
Accessory Apt					
Foundation Alt	11	Stone Ftgs			
Rms Prts					
Bath Split	A0	10 Full-0 Half			
			CONDO DATA		
			Parcel Id	C	Ownr 0.0
			Adjust Type Code Description Factor%		
			Condo Flr		
			Condo Unit		
			COST / MARKET VALUATION		
			Building Value New	661,401	
			Year Built	1820	
			Effective Year Built	1984	
			Depreciation Code	A	
			Remodel Rating		
			Year Remodeled		
			Depreciation %	31	
			Functional Obsol	5	
			External Obsol	0	
			Trend Factor	1	
			Condition		
			Condition %		
			Percent Good	64	
			RCNLD	423,300	
			Dep % Ovr		
			Dep Ovr Comment		
			Misc Imp Ovr		
			Misc Imp Ovr Comment		
			Cost to Cure Ovr		
			Cost to Cure Ovr Comment		

OB - OUTBUILDING & YARD ITEMS(L) / XF - BUILDING EXTRA FEATURES(B)										
Code	Description	L/B	Units	Unit Price	Yr Blt	Cond. Cd	% Gd	Grade	Grade Adj.	Appr. Value
FPL3	Fireplace 2 sto	B	3	7000.00	1979		64		0.00	13,400
FPO	Ext FP Openin	B	1	2000.00	1979		64		0.00	1,300
FGR1	Garage-Poor-	L	5,080	40.00	1999		75	D	0.85	129,500
WDC	Wood Decking	L	550	20.00	1996		54		0.00	5,500
PAT2	Patio-Good	L	280	9.94	1996		77		0.00	2,200
FOP	Open Porch-ro	B	691	55.00	1979		64		0.00	16,700
SHED	Shed	L	48	18.00	2019		100		0.00	900
SHED	Shed	L	96	18.00	2019		100		0.00	1,700

BUILDING SUB-AREA SUMMARY SECTION						
Code	Description	Living Area	Floor Area	Eff Area	Unit Cost	Undeprec Value
BAS	First Floor	2,644	2,644	2,644	152.01	401,918
FOP	Open Porch	0	691	0	0.00	0
FUS	Upper Story	1,707	1,707	1,707	152.01	259,483
PTO	Patio	0	280	0	0.00	0
WDK	Wood Deck	0	550	0	0.00	0
Ttl Gross Liv / Lease Area		4,351	5,872	4,351		661,401

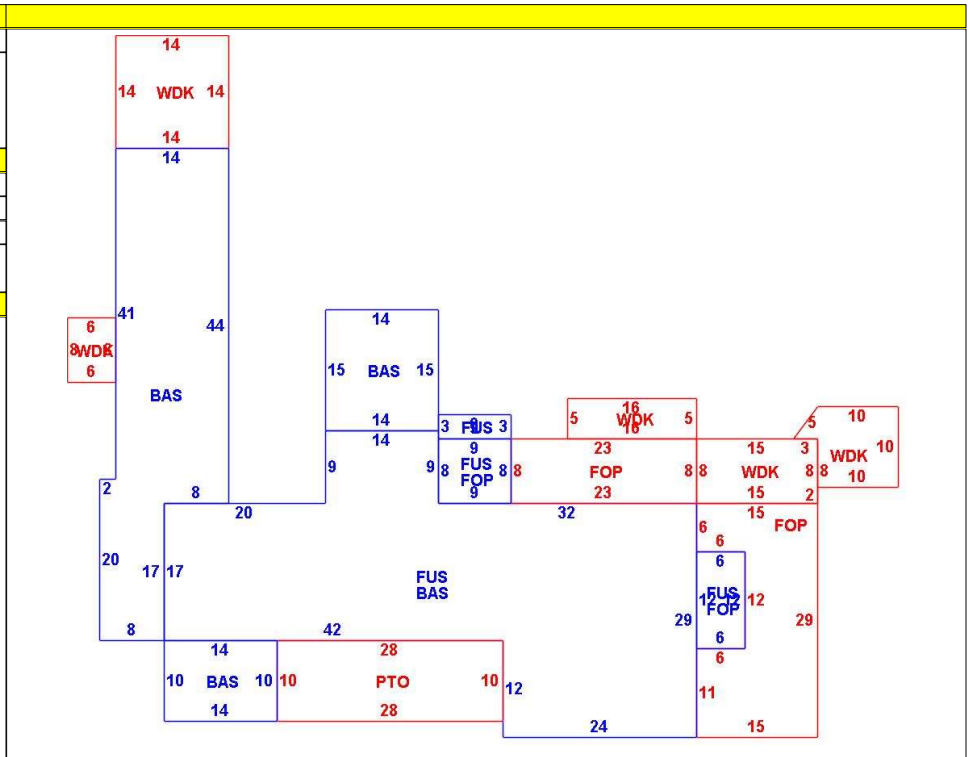

CURRENT OWNER		TOPO	UTILITIES	STRT / ROAD	LOCATION	CURRENT ASSESSMENT				
PUTNAM, WILLIAM B JR TR WILLIAM B PUTNAM JR TRUST 288 SCUDDER AVENUE						Description	Code	Assessed	Assessed	801 FY2025 BARNSTABLE, MA
HYANNIS MA 02601					4	RESIDENTI RES LAND	1259 1259	1,004,500 200,000	1,004,500 200,000	
SUPPLEMENTAL DATA										VISION
Alt Prcl ID Split Zonin BID Parcel ResExpt Q YES: #DL 1 LOT 9 #DL 2 GIS ID F_983199_2696503			Plan Ref. Land Ct# 36483-D #SR Life Estate PP STATU Assoc Pid#							
						Total		1,204,500	1,204,500	

RECORD OF OWNERSHIP		BK-VOL/PAGE	SALE DATE	Q/U	V/I	SALE PRIC	VC	PREVIOUS ASSESSMENTS (HISTORY)									
PUTNAM, WILLIAM B JR TR		C235745 0	04-25-2024	U	I	1	1F	Year	Code	Assessed	Year	Code	Assessed V	Year	Code	Assessed	
PUTMAN, WILLIAM B JR		C114955 0	07-15-1988	Q	I	650,000	U	2025	1259	1,004,500	2024	1259	1,004,500	2023	1259	924,200	
HOFMANN, RICHARD		C105851 0	04-15-1986	Q	I	225,000	U		1259	200,000		1259	200,000		1259	200,000	
NICKULAS, LARRY		C97479 0	07-15-1984	Q	V	1	U										
NICKULAS, LARRY		C97479 0	07-15-1984	U	V	1	R										
Total								1,204,500		Total		1,204,500		Total		1,124,200	

EXEMPTIONS				OTHER ASSESSMENTS				This signature acknowledges a visit by a Data Collector or Assessor										
Year	Code	Description	Amount	Code	Description	Number	Amount	Comm Int										
2022	5C	RESIDENTIAL EXEMPTION	0.00															
Total			0.00															

ASSESSING NEIGHBORHOOD				APPRAISED VALUE SUMMARY													
Nbhd	Nbhd Name		B	Tracing		Batch											
0109						HYAN											

NOTES														APPRAISED VALUE SUMMARY				
RENTED AS 2 BEDROOM SUITE														Appraised Bldg. Value (Card)				802,300
														Appraised Xf (B) Value (Bldg)				52,800
														Appraised Ob (B) Value (Bldg)				149,400
														Appraised Land Value (Bldg)				200,000
														Special Land Value				0
														Total Appraised Parcel Value				1,204,500
														Valuation Method				I
														Total Appraised Parcel Value				1,204,500

BUILDING PERMIT RECORD										VISIT / CHANGE HISTORY					
Permit Id	Issue Date	Type	Description	Amount	Insp Date	% Comp	Date Comp	Comments		Date	Id	Type	Is	Cd	Purpost/Result

LAND LINE VALUATION SECTION																		
B	Use Code	Description	Zone	LA	Land Units	Unit Price	Size Adj	AC Disc	Site Index	Cond.	Nbhd.	Nbhd. Adj	Notes		Location Adjustmen	Adj Unit P	Land Value	
2	1259	B&B	RB	4	0 SF	0.00	1.00000	1.0000	5	1.00	0109	2.200			0.0000	0	0	
Total Card Land Units					0.00	SF	Parcel Total Land Area					1.10	Total Land Value					0

