

CURRENT OWNER		TOPO	UTILITIES	STRT / ROAD	LOCATION	CURRENT ASSESSMENT				801 FY2025 BARNSTABLE, MA VISION	
PETRIE, KAREN ANN & INCUTTO, MI 119 PITCHERS WAY HYANNIS MA 02601	1	Level	2	Public Water	1	Paved	Description	Code	Assessed		Assessed
	4	Gas					RESIDNTL	1010	281,500		281,500
	6	Septic			4		RES LAND	1010	151,300		151,300
SUPPLEMENTAL DATA						Total				432,800	432,800
Alt Prcl ID		Split Zonin		Plan Ref. 85/39							
BID Parcel		ResExpt Q YES:		Land Ct#							
#DL 1 LOT 5		#DL 2		Life Estate							
GIS ID F_983014_2697790		Assoc Pid#									

RECORD OF OWNERSHIP		BK-VOL/PAGE	SALE DATE	Q/U	V/I	SALE PRIC	VC	PREVIOUS ASSESSMENTS (HISTORY)								
PETRIE, KAREN ANN & INCUTTO, MICH ELLSWORTH, PHILIP J & JOAN A	15616	0218	09-19-2002	Q	I	235,000	00	Year	Code	Assessed	Year	Code	Assessed			
	2552	0075	07-22-1977	U		0		2025	1010	281,500	2024	1010	267,500			
									1010	151,300		1010	151,300			
								Total		432,800	Total		418,800	Total		375,700

EXEMPTIONS				OTHER ASSESSMENTS				This signature acknowledges a visit by a Data Collector or Assessor				
Year	Code	Description	Amount	Code	Description	Number	Amount	Comm Int				
2010	5C	RESIDENTIAL EXEMPTION	0.00									
Total			0.00									

ASSESSING NEIGHBORHOOD				APPRAISED VALUE SUMMARY			
Nbhd	Nbhd Name	B	Tracing	Batch			
0105				HYAN			

NOTES				APPRAISED VALUE SUMMARY			
				Appraised Bldg. Value (Card)	245,900		
				Appraised Xf (B) Value (Bldg)	28,300		
				Appraised Ob (B) Value (Bldg)	7,300		
				Appraised Land Value (Bldg)	151,300		
				Special Land Value	0		
				Total Appraised Parcel Value	432,800		
				Valuation Method	C		
				Total Appraised Parcel Value	432,800		

BUILDING PERMIT RECORD								VISIT / CHANGE HISTORY						
Permit Id	Issue Date	Type	Description	Amount	Insp Date	% Comp	Date Comp	Comments	Date	Id	Type	Is	Cd	Purpost/Result
									05-26-2020	WD			FR	Field Review
									04-25-2016	MS	03		16	In Office Review
									01-22-2015	SR	02		14	Cyclical Inspection
									12-17-2002	PT	01		00	Meas/Listed-Interior Acces
									02-21-2002	PT	01		00	Meas/Listed-Interior Acces
									07-15-1988	ML	01		00	Meas/Listed-Interior Acces

LAND LINE VALUATION SECTION																	
B	Use Code	Description	Zone	LA	Land Units	Unit Price	Size Adj	AC Disc	Site Index	Cond.	Nbhd.	Nbhd. Adj	Notes	Location Adjustmen	Adj Unit P	Land Value	
1	1010	Single Fam M-0	RB	4	0.320	AC	176,344.00	2.68059	1.0000	5	1.00	0105	1.000		1.0000	472,707.7	151,300
Total Card Land Units					0.32	AC	Parcel Total Land Area					0.32	Total Land Value			151,300	

CONSTRUCTION DETAIL			CONSTRUCTION DETAIL (CONTINUED)		
Element	Cd	Description	Element	Cd	Description
Style	04	Cape Cod			
Model	01	Residential			
Grade:	C	Average			
Stories	1.4				
Exterior Wall 1	14	Wood Shingle			
Exterior Wall 2	11	Clapboard			
RooF Structure	03	Gable/Hip			
RooF Cover	03	Asph/F Gls/Cmp			
Interior Wall 1	05	Drywall			
Interior Wall 2					
Interior Floor 1	12	Hardwood			
Interior Floor 2	11	Ceram Clay Til			
Heat Fuel	02	Oil			
Heat Type	05	Hot Water			
AC Type	01	None			
Bedrooms	03	3 Bedrooms			
Full Baths	1				
Half Baths	0				
Extra Fixtures					
Total Rooms	5	5 Rooms			
Bath Style					
Kitchen Style					
Occupancy					
Sewer Occupan					
Accessory Apt					
Foundation Alt	02	Conc. Block			
Rms Prts					
Bath Split	10	1 Full-0 Half			

CONDO DATA			
Parcel Id		C	Owne 0.0
Adjust Type	Code	Description	Factor%
Condo Flr			
Condo Unit			

COST / MARKET VALUATION	
Building Value New	356,325
Year Built	1949
Effective Year Built	1984
Depreciation Code	A
Remodel Rating	
Year Remodeled	
Depreciation %	31
Functional Obsol	0
External Obsol	0
Trend Factor	1
Condition	
Condition %	
Percent Good	69
RCNLD	245,900
Dep % Ovr	
Dep Ovr Comment	
Misc Imp Ovr	
Misc Imp Ovr Comment	
Cost to Cure Ovr	
Cost to Cure Ovr Comment	

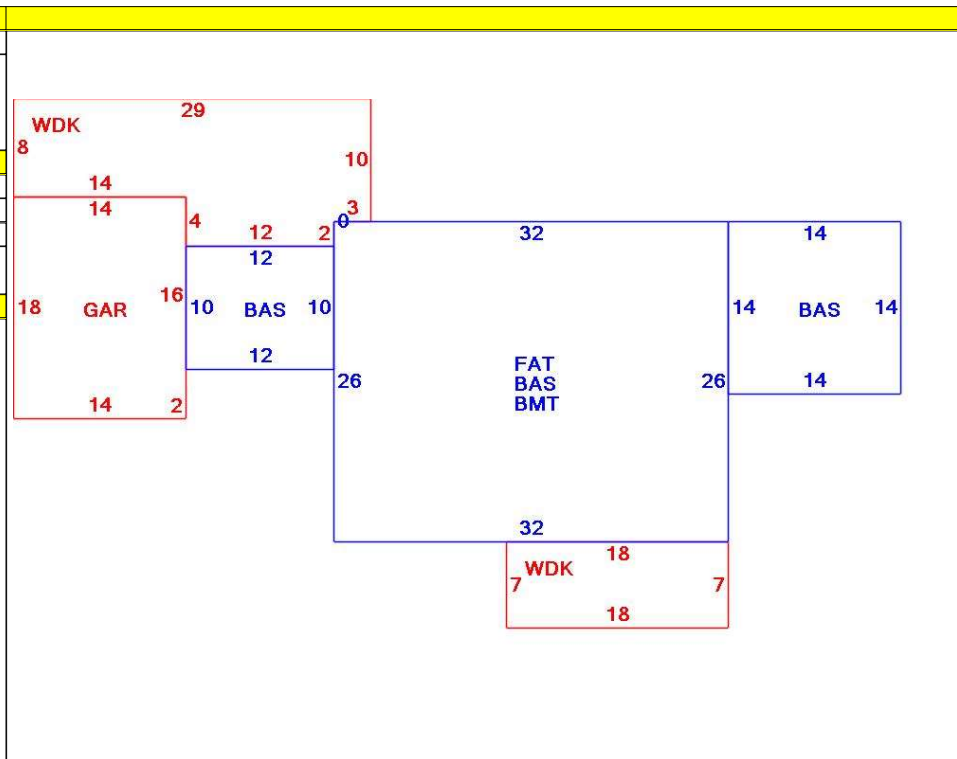

OB - OUTBUILDING & YARD ITEMS(L) / XF - BUILDING EXTRA FEATURES(B)										
Code	Description	L/B	Units	Unit Price	Yr Blt	Cond. Cd	% Gd	Grade	Grade Adj.	Appr. Value
FPL2	Fireplace 1.5 s	B	1	6000.00	1982		69		0.00	4,100
GAR	Attached Gara	B	252	40.00	1982		69		0.00	8,100
BMT	Basement-Unfi	B	832	26.01	1982		69		0.00	16,100
WDC	Wood Decking	L	412	20.00	2015		92		0.00	7,300

BUILDING SUB-AREA SUMMARY SECTION						
Code	Description	Living Area	Floor Area	Eff Area	Unit Cost	Undeprec Value
BAS	First Floor	1,148	1,148	1,148	279.91	321,337
BMT	Basement Area	0	832	0	0.00	0
FAT	Attic, Finished	125	832	125	42.05	34,989
GAR	Attached Garage	0	252	0	0.00	0
WDC	Wood Deck	0	412	0	0.00	0
Ttl Gross Liv / Lease Area		1,273	3,476	1,273		356,326

