

CURRENT OWNER		TOPO	UTILITIES	STRT / ROAD	LOCATION	CURRENT ASSESSMENT				801 FY2025 BARNSTABLE, MA
ANDERSON, BRETT C TR THE FORTY-TWO TRUST PO BOX 2701 HYANNIS MA 02601		1 Level	2 Public Water	1 Paved	1 Lake/Pond Fro	Description	Code	Assessed	Assessed	
			4 Gas			RESIDNTL	1010	334,500	334,500	
			6 Septic		4	RES LAND	1010	166,700	166,700	
SUPPLEMENTAL DATA										
Alt Prcl ID Split Zonin BID Parcel ResExpt Q YES: #DL 1 LOTS 4 & 5 #DL 2 GIS ID F_983545_2697811					Plan Ref. Land Ct# 24740-B #SR Life Estate PP STATU D:Deleted Assoc Pid#		Total		501,200	501,200

VISION

RECORD OF OWNERSHIP		BK-VOL/PAGE	SALE DATE	Q/U	V/I	SALE PRIC	VC	PREVIOUS ASSESSMENTS (HISTORY)									
ANDERSON, BRETT C TR		C226655	0	06-18-2021	U	I	1	1F	Year	Code	Assessed	Year	Code	Assessed			
ANDERSON, BRETT C		C214697	0	11-17-2017	U	I	100	1F	2025	1010	334,500	2024	1010	332,200			
ANDERSON, BRETT C & PAULA E		C167124	0	10-31-2002	U	I	100	1A		1010	166,700	2023	1010	293,500			
KOTSEAS, CHARLES H		C74659	0	06-27-1978	U		0						1010	151,600			
									Total		501,200	Total		498,900	Total		445,100

EXEMPTIONS			OTHER ASSESSMENTS					This signature acknowledges a visit by a Data Collector or Assessor										
Year	Code	Description	Amount	Code	Description	Number	Amount	Comm Int										
2025	5C	RESIDENTIAL EXEMPTION																
Total			0.00															

ASSESSING NEIGHBORHOOD				APPRAISED VALUE SUMMARY										
Nbhd	Nbhd Name	B	Tracing	Batch										
0105				HYAN										
NOTES														
Appraised Bldg. Value (Card) 270,300 Appraised Xf (B) Value (Bldg) 60,100 Appraised Ob (B) Value (Bldg) 4,100 Appraised Land Value (Bldg) 166,700 Special Land Value 0 Total Appraised Parcel Value 501,200 Valuation Method C Total Appraised Parcel Value 501,200														

BUILDING PERMIT RECORD										VISIT / CHANGE HISTORY					
Permit Id	Issue Date	Type	Description	Amount	Insp Date	% Comp	Date Comp	Comments		Date	Id	Type	Is	Cd	Purpost/Result
										08-13-2024	EG	03		16	In Office Review
										07-25-2024	AG	22		22	Change of Address
										05-06-2022	BM	22		22	Change of Address
										05-26-2020	WD			FR	Field Review
										02-14-2018	SR	02		03	Cycl Insp Comp
										06-23-2016	AL	22		22	Change of Address
										02-11-2002	PT	01		00	Meas/Listed-Interior Acces

LAND LINE VALUATION SECTION																	
B	Use Code	Description	Zone	LA	Land Units	Unit Price	Size Adj	AC Disc	Site Index	Cond.	Nbhd.	Nbhd. Adj	Notes	Location Adjustmen	Adj Unit P	Land Value	
1	1010	Single Fam M-0	RB	4	0.630	AC	176,344.00	1.50069	1.0000	5	1.00	0105	1.000		1.0000	264,639.4	166,700
Total Card Land Units					0.63	AC	Parcel Total Land Area					0.63	Total Land Value			166,700	

CONSTRUCTION DETAIL			CONSTRUCTION DETAIL (CONTINUED)		
Element	Cd	Description	Element	Cd	Description
Style	01	Ranch			
Model	01	Residential			
Grade:	C	Average			
Stories	1	1 Story			
Exterior Wall 1	14	Wood Shingle			
Exterior Wall 2					
RooF Structure	03	Gable/Hip			
RooF Cover	03	Asph/F Gls/Cmp			
Interior Wall 1	05	Drywall			
Interior Wall 2					
Interior Floor 1	14	Carpet			
Interior Floor 2					
Heat Fuel	02	Oil			
Heat Type	05	Hot Water			
AC Type	01	None			
Bedrooms	04	4 Bedrooms			
Full Baths	2				
Half Baths	1				
Extra Fixtures					
Total Rooms	7	7 Rooms			
Bath Style					
Kitchen Style					
Occupancy					
Sewer Occupan					
Accessory Apt					
Foundation Alt	01	Poured Conc.			
Rms Prts					
Bath Split	21	2 Full-1 Half			
			CONDO DATA		
			Parcel Id	C	Ownr 0.0
				B	S
			Adjust Type	Code	Description
			Condo Flr		
			Condo Unit		
			COST / MARKET VALUATION		
			Building Value New		360,363
			Year Built		1965
			Effective Year Built		1992
			Depreciation Code		A
			Remodel Rating		
			Year Remodeled		
			Depreciation %		25
			Functional Obsol		0
			External Obsol		0
			Trend Factor		1
			Condition		
			Condition %		
			Percent Good		75
			RCNLD		270,300
			Dep % Ovr		
			Dep Ovr Comment		
			Misc Imp Ovr		
			Misc Imp Ovr Comment		
			Cost to Cure Ovr		
			Cost to Cure Ovr Comment		

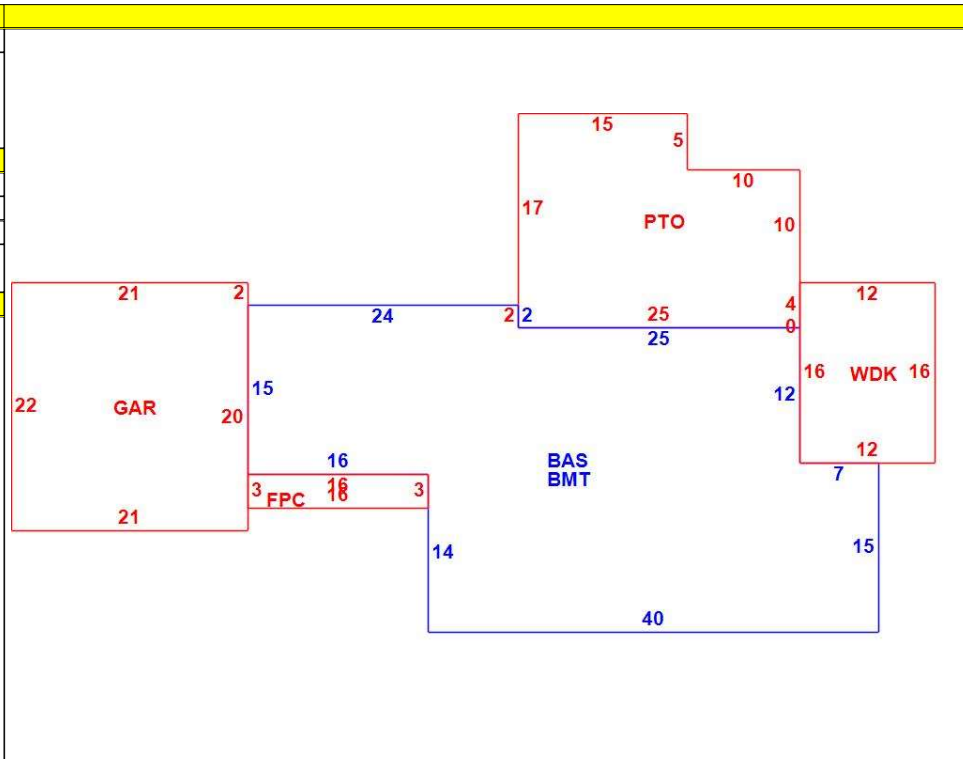

OB - OUTBUILDING & YARD ITEMS(L) / XF - BUILDING EXTRA FEATURES(B)										
Code	Description	L/B	Units	Unit Price	Yr Blt	Cond. Cd	% Gd	Grade	Grade Adj.	Appr. Value
FPL1	Fireplace 1 sto	B	1	5000.00	1990		75		0.00	3,800
FPO	Ext FP Openin	B	1	2000.00	1990		75		0.00	1,500
BFA	Bsmt Fin-Avg	B	1,252	17.36	1990		75		0.00	16,300
WDC	Wood Decking	L	192	20.00	1994		50		0.00	2,300
PAT1	Patio- Average	L	425	5.89	1994		75		0.00	1,800
FOPC	Open Prch-roo	B	48	55.00	1990		75		0.00	2,100
GAR	Attached Gara	B	462	40.00	1990		75		0.00	13,200
BMT	Basement-Unfi	B	1,252	26.01	1990		75		0.00	23,200

BUILDING SUB-AREA SUMMARY SECTION						
Code	Description	Living Area	Floor Area	Eff Area	Unit Cost	Undeprec Value
BAS	First Floor	1,252	1,252	1,252	287.83	360,363
BMT	Basement Area	0	1,252	0	0.00	0
FPC	Open Porch Conc. Floor	0	48	0	0.00	0
GAR	Attached Garage	0	462	0	0.00	0
PTO	Patio	0	425	0	0.00	0
WDK	Wood Deck	0	192	0	0.00	0
Ttl Gross Liv / Lease Area		1,252	3,631	1,252		360,363

