

| CURRENT OWNER | | TOPO | UTILITIES | STRT / ROAD | LOCATION | CURRENT ASSESSMENT | | | | 801 FY2025 BARNSTABLE, MA VISION | |
|---|--|---------|----------------|---|----------|--------------------|------|----------|----------|--|---------|
| JACOBSON, KIRILL & IRINA 11 EATON STREET WINCHESTER MA 01890 | | 1 Level | 2 Public Water | 1 Paved | | Description | Code | Assessed | Assessed | | |
| | | | 4 Gas | | | RESIDNTL | 1010 | 267,300 | 267,300 | | |
| | | | 6 Septic | | 4 | RES LAND | 1010 | 172,100 | 172,100 | | |
| SUPPLEMENTAL DATA | | | | | | Total | | | | 439,400 | 439,400 |
| Alt Prcl ID Split Zonin BID Parcel ResExpt Q #DL 1 LOT 21 #DL 2 GIS ID F_983814_2697150 | | | | Plan Ref. 38/91 Land Ct# #SR Life Estate PP STATU Assoc Pid# | | | | | | | |

| RECORD OF OWNERSHIP | | BK-VOL/PAGE | SALE DATE | Q/U | V/I | SALE PRIC | VC | PREVIOUS ASSESSMENTS (HISTORY) | | | | | | | |
|----------------------------------|-------|-------------|------------|-----|-----|-----------|----|--------------------------------|------|----------|------|---------|----------|-------|---------|
| JACOBSON, KIRILL & IRINA | 29423 | 0126 | 01-29-2016 | Q | I | 230,000 | 00 | Year | Code | Assessed | Year | Code | Assessed | | |
| ZULLO, TERRI | 24335 | 0084 | 01-29-2010 | Q | I | 254,410 | 00 | 2025 | 1010 | 267,300 | 2024 | 1010 | 265,100 | | |
| HANSEN, ALUN R & SHAUGHNESSY, JO | 14458 | 0197 | 11-19-2001 | Q | I | 212,000 | 00 | | 1010 | 172,100 | 2023 | 1010 | 227,800 | | |
| MORIN, JEFFREY M & PATRICIA | 7192 | 0035 | 06-15-1990 | Q | I | 85,000 | 00 | | | | | | | | |
| SHAW, ROBBIE E | 1512 | 0453 | 05-28-1971 | U | | 0 | | | | | | | | | |
| Total | | | | | | | | 439,400 | | Total | | 437,200 | | Total | 397,800 |

| EXEMPTIONS | | | OTHER ASSESSMENTS | | | | This signature acknowledges a visit by a Data Collector or Assessor | | | | | | |
|------------|------|-------------|-------------------|------|-------------|--------|---|------|-----|--|--|--|--|
| Year | Code | Description | Amount | Code | Description | Number | Amount | Comm | Int | | | | |
| | | | | | | | | | | | | | |
| Total | | | 0.00 | | | | | | | | | | |

| ASSESSING NEIGHBORHOOD | | | | APPRAISED VALUE SUMMARY | | | |
|------------------------|-----------|---|---------|-------------------------|-------------------------------|---------|--|
| Nbhd | Nbhd Name | B | Tracing | Batch | | | |
| 0106 | | | | HYAN | Appraised Bldg. Value (Card) | 237,400 | |
| | | | | | Appraised Xf (B) Value (Bldg) | 24,000 | |
| | | | | | Appraised Ob (B) Value (Bldg) | 5,900 | |
| | | | | | Appraised Land Value (Bldg) | 172,100 | |
| | | | | | Special Land Value | 0 | |
| | | | | | Total Appraised Parcel Value | 439,400 | |
| | | | | | Valuation Method | C | |
| | | | | | Total Appraised Parcel Value | 439,400 | |

| NOTES | | | | | | | | | | VISIT / CHANGE HISTORY | | | | | |
|-------|--|--|--|--|--|--|--|--|--|------------------------|----|------|----|----|----------------------------|
| | | | | | | | | | | Date | Id | Type | Is | Cd | Purpost/Result |
| | | | | | | | | | | 05-26-2020 | WD | | | FR | Field Review |
| | | | | | | | | | | 01-26-2018 | SR | 01 | | 03 | Cycl Insp Comp |
| | | | | | | | | | | 02-12-2002 | PT | 01 | | 00 | Meas/Listed-Interior Acces |
| | | | | | | | | | | 06-15-1988 | ML | 01 | | 00 | Meas/Listed-Interior Acces |

| BUILDING PERMIT RECORD | | | | | | | | | | LAND LINE VALUATION SECTION | | | | | |
|------------------------|------------|------|----------------|--------|-----------|--------|-----------|----------------------------------|--|-----------------------------|----|------|----|----|----------------|
| Permit Id | Issue Date | Type | Description | Amount | Insp Date | % Comp | Date Comp | Comments | | Date | Id | Type | Is | Cd | Purpost/Result |
| 17-478 | 02-22-2017 | 835 | Sid/Wind/Roof/ | 12,500 | | 100 | | Re-Roof (stripping old shingles) | | 05-26-2020 | WD | | | FR | Field Review |

| B | Use Code | Description | Zone | LA | Land Units | Unit Price | Size Adj | AC Disc | Site Index | Cond. | Nbhd. | Nbhd. Adj | Notes | Location Adjustmen | Adj Unit P | Land Value | |
|---|----------|----------------|------|----|------------|------------|------------|---------|------------|-------|-------|-----------|-------|--------------------|------------|------------|---------|
| 1 | 1010 | Single Fam M-0 | RB | 4 | 0.270 | AC | 176,344.00 | 3.14262 | 1.0000 | 5 | 1.00 | 0106 | 1.150 | | 1.0000 | 637,307.2 | 172,100 |

| CONSTRUCTION DETAIL | | | CONSTRUCTION DETAIL (CONTINUED) | | |
|---------------------|----|----------------|---------------------------------|----|-------------|
| Element | Cd | Description | Element | Cd | Description |
| Style | 01 | Ranch | | | |
| Model | 01 | Residential | | | |
| Grade: | C | Average | | | |
| Stories | 1 | 1 Story | | | |
| Exterior Wall 1 | 14 | Wood Shingle | | | |
| Exterior Wall 2 | 11 | Clapboard | | | |
| Roof Structure | 03 | Gable/Hip | | | |
| Roof Cover | 03 | Asph/F Gls/Cmp | | | |
| Interior Wall 1 | 05 | Drywall | | | |
| Interior Wall 2 | | | | | |
| Interior Floor 1 | 12 | Hardwood | | | |
| Interior Floor 2 | | | | | |
| Heat Fuel | 03 | Gas | | | |
| Heat Type | 05 | Hot Water | | | |
| AC Type | 01 | None | | | |
| Bedrooms | 03 | 3 Bedrooms | | | |
| Full Baths | 1 | | | | |
| Half Baths | 0 | | | | |
| Extra Fixtures | | | | | |
| Total Rooms | 6 | 6 Rooms | | | |
| Bath Style | | | | | |
| Kitchen Style | | | | | |
| Occupancy | | | | | |
| Sewer Occupan | | | | | |
| Accessory Apt | | | | | |
| Foundation Alt | 02 | Conc. Block | | | |
| Rms Prts | | | | | |
| Bath Split | 10 | 1 Full-0 Half | | | |

| CONDO DATA | | | |
|-------------|------|-------------|----------|
| Parcel Id | | C | Ownr 0.0 |
| Adjust Type | Code | Description | Factor% |
| Condo Flr | | | |
| Condo Unit | | | |

| COST / MARKET VALUATION | |
|--------------------------|---------|
| Building Value New | 344,087 |
| Year Built | 1948 |
| Effective Year Built | 1984 |
| Depreciation Code | A |
| Remodel Rating | |
| Year Remodeled | |
| Depreciation % | 31 |
| Functional Obsol | 0 |
| External Obsol | 0 |
| Trend Factor | 1 |
| Condition | |
| Condition % | |
| Percent Good | 69 |
| RCNLD | 237,400 |
| Dep % Ovr | |
| Dep Ovr Comment | |
| Misc Imp Ovr | |
| Misc Imp Ovr Comment | |
| Cost to Cure Ovr | |
| Cost to Cure Ovr Comment | |

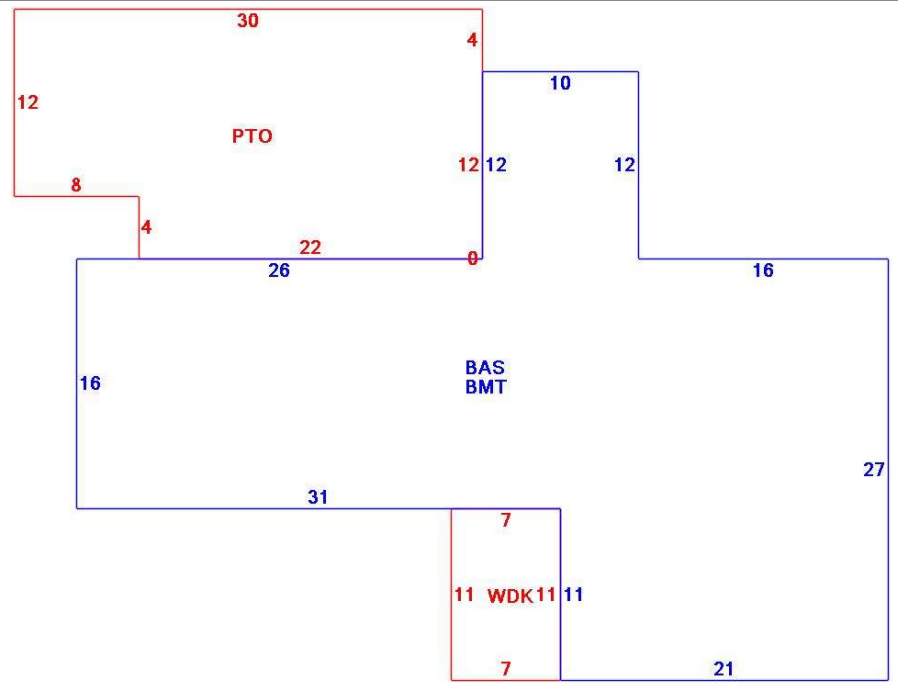

| OB - OUTBUILDING & YARD ITEMS(L) / XF - BUILDING EXTRA FEATURES(B) | | | | | | | | | | |
|--|-----------------|-----|-------|------------|--------|----------|------|-------|------------|-------------|
| Code | Description | L/B | Units | Unit Price | Yr Blt | Cond. Cd | % Gd | Grade | Grade Adj. | Appr. Value |
| FPL1 | Fireplace 1 sto | B | 1 | 5000.00 | 1982 | | 69 | | 0.00 | 3,500 |
| WDC | Wood Decking | L | 77 | 20.00 | 1990 | | 42 | | 0.00 | 1,400 |
| PAT2 | Patio-Good | L | 448 | 9.94 | 1990 | | 71 | | 0.00 | 3,100 |
| BMT | Basement-Unfi | B | 1,183 | 26.01 | 1982 | | 69 | | 0.00 | 20,500 |
| SHED | Shed | L | 80 | 18.00 | 2019 | | 100 | | 0.00 | 1,400 |

| BUILDING SUB-AREA SUMMARY SECTION | | | | | | |
|-----------------------------------|---------------|-------------|------------|----------|-----------|----------------|
| Code | Description | Living Area | Floor Area | Eff Area | Unit Cost | Undeprec Value |
| BAS | First Floor | 1,183 | 1,183 | 1,183 | 290.86 | 344,087 |
| BMT | Basement Area | 0 | 1,183 | 0 | 0.00 | 0 |
| PTO | Patio | 0 | 448 | 0 | 0.00 | 0 |
| WDK | Wood Deck | 0 | 77 | 0 | 0.00 | 0 |
| Ttl Gross Liv / Lease Area | | 1,183 | 2,891 | 1,183 | | 344,087 |

