

CONSTRUCTION DETAIL			CONSTRUCTION DETAIL (CONTINUED)		
Element	Cd	Description	Element	Cd	Description
Style	01	Ranch			
Model	01	Residential			
Grade:	C+	Average Plus			
Stories	1	1 Story			
Exterior Wall 1	14	Wood Shingle			
Exterior Wall 2	25	Vinyl Siding			
RooF Structure	03	Gable/Hip			
RooF Cover	03	Asph/F Gls/Cmp			
Interior Wall 1	05	Drywall			
Interior Wall 2					
Interior Floor 1	14	Carpet			
Interior Floor 2	12	Hardwood			
Heat Fuel	03	Gas			
Heat Type	05	Hot Water			
AC Type	01	None			
Bedrooms	03	3 Bedrooms			
Full Baths	2				
Half Baths	0				
Extra Fixtures					
Total Rooms	8	8 Rooms			
Bath Style					
Kitchen Style					
Occupancy					
Sewer Occupan					
Accessory Apt					
Foundation Alt	01	Poured Conc.			
Rms Prts					
Bath Split	20	2 Full-0 Half			
			CONDO DATA		
Parcel Id			C	Owne	0.0
Adjust Type			B	S	
Condo Flr					
Condo Unit					
			COST / MARKET VALUATION		
Building Value New				443,560	
Year Built				1978	
Effective Year Built				2004	
Depreciation Code				G	
Remodel Rating					
Year Remodeled					
Depreciation %				16	
Functional Obsol				0	
External Obsol				0	
Trend Factor				1	
Condition					
Condition %					
Percent Good				84	
RCNLD				372,600	
Dep % Ovr					
Dep Ovr Comment					
Misc Imp Ovr					
Misc Imp Ovr Comment					
Cost to Cure Ovr					
Cost to Cure Ovr Comment					

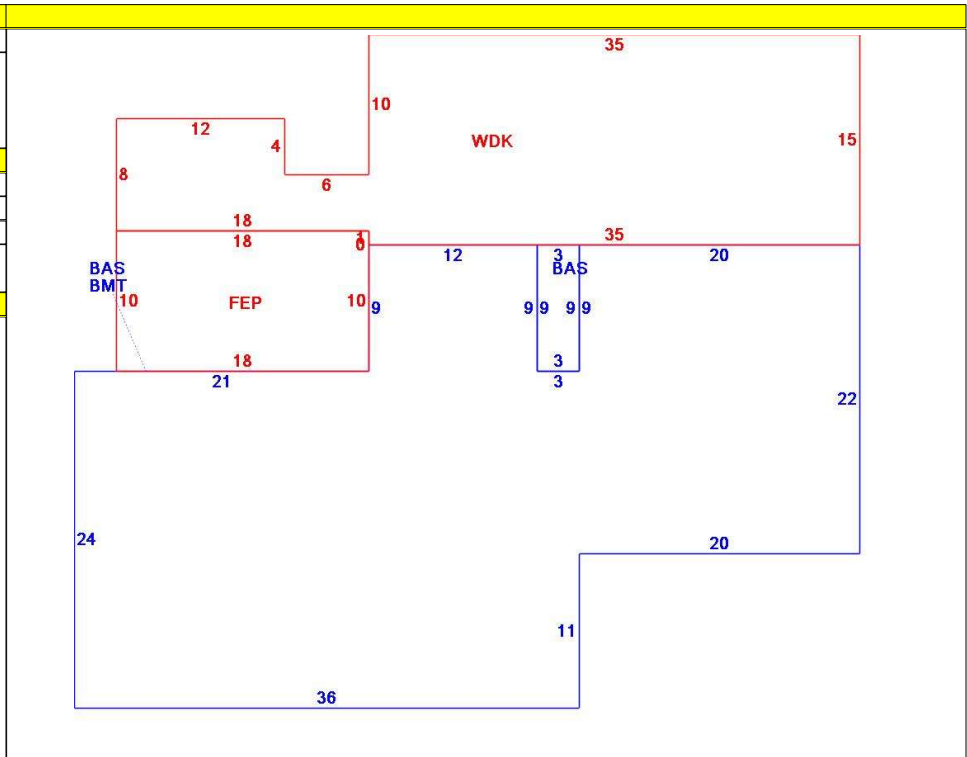

OB - OUTBUILDING & YARD ITEMS(L) / XF - BUILDING EXTRA FEATURES(B)										
Code	Description	L/B	Units	Unit Price	Yr Blt	Cond. Cd	% Gd	Grade	Grade Adj.	Appr. Value
FPL1	Fireplace 1 sto	B	1	5000.00	2002		84		0.00	4,200
BGR2	2 Stall Bmt Ga	B	1	3244.00	2002		84		0.00	2,700
BFA	Bsmt Fin-Avg	B	800	17.36	2002		84		0.00	11,700
WDC	Wood Decking	L	645	20.00	2002		66		0.00	7,800
FEP	Enclosed porc	B	180	70.00	2002		84		0.00	9,900
BMT	Basement-Unfi	B	1,412	26.01	2002		84		0.00	28,500
PAT1	Patio- Average	L	104	5.89	2015		96		0.00	700

BUILDING SUB-AREA SUMMARY SECTION						
Code	Description	Living Area	Floor Area	Eff Area	Unit Cost	Undeprec Value
BAS	First Floor	1,439	1,439	1,439	308.24	443,560
BMT	Basement Area	0	1,412	0	0.00	0
FEP	Enclosed Porch	0	180	0	0.00	0
WDK	Wood Deck	0	645	0	0.00	0
Ttl Gross Liv / Lease Area		1,439	3,676	1,439		443,560

