

| CURRENT OWNER | | TOPO | UTILITIES | STRT / ROAD | LOCATION | CURRENT ASSESSMENT | | | | 801 FY2025 BARNSTABLE, MA VISION | |
|---|--|---------|----------------|--|----------|--------------------|------|----------|----------|--|-----------|
| PORTER, BRIAN & SUSAN 886 MAIN STREET COTUIT MA 02635 | | 1 Level | 6 Septic | 1 Paved | | Description | Code | Assessed | Assessed | | |
| | | | 4 Gas | | | RESIDENTL | 1010 | 785,800 | 785,800 | | |
| | | | 2 Public Water | | 2 | RES LAND | 1010 | 855,400 | 855,400 | | |
| SUPPLEMENTAL DATA | | | | | | Total | | | | 1,641,200 | 1,641,200 |
| Alt Prcl ID Split Zonin BID Parcel ResExpt Q YES: #DL 1 LOT A #DL 2 GIS ID F_947489_2687530 | | | | Plan Ref. 110/55 Land Ct# #SR Life Estate PP STATU Assoc Pid# | | | | | | | |

| RECORD OF OWNERSHIP | | BK-VOL/PAGE | SALE DATE | Q/U | V/I | SALE PRIC | VC | PREVIOUS ASSESSMENTS (HISTORY) | | | | | | | | |
|------------------------------------|--|-------------|-----------|------------|-----|-----------|-----------|--------------------------------|-----------|------|----------|------|-----------|----------|-------|-----------|
| PORTER, BRIAN & SUSAN | | 32614 | 0073 | 01-10-2020 | Q | I | 1,075,000 | 00 | Year | Code | Assessed | Year | Code | Assessed | | |
| GARDNER, AMY L TR | | 28970 | 0337 | 06-26-2015 | Q | I | 653,500 | 00 | 2025 | 1010 | 785,800 | 2024 | 1010 | 735,800 | | |
| BARNABY, ELLEN & SUSAN A, O'TOOLE, | | 28970 | 0329 | 06-26-2015 | U | I | 0 | 1A | | 1010 | 855,400 | | 1010 | 855,400 | | |
| BARNABY, JANE I | | 16117 | 0279 | 12-20-2002 | U | I | 10 | 1A | | | | | | | | |
| BARNABY, JANE I | | 16117 | 0276 | 12-20-2002 | U | I | 10 | 1F | | | | | | | | |
| Total | | | | | | | | | 1,641,200 | | Total | | 1,591,200 | | Total | 1,332,400 |

| EXEMPTIONS | | | | OTHER ASSESSMENTS | | | | This signature acknowledges a visit by a Data Collector or Assessor | | | | | | | | |
|------------|------|-----------------------|--------|-------------------|-------------|--------|--------|---|--|--|--|--|--|--|--|--|
| Year | Code | Description | Amount | Code | Description | Number | Amount | Comm Int | | | | | | | | |
| 2022 | 5C | RESIDENTIAL EXEMPTION | 0.00 | | | | | | | | | | | | | |
| Total | | | 0.00 | | | | | | | | | | | | | |

| ASSESSING NEIGHBORHOOD | | | | APPRAISED VALUE SUMMARY | | | |
|------------------------|-----------|---|---------|-------------------------|--|--|--|
| Nbhd | Nbhd Name | B | Tracing | Batch | | | |
| 0112 | | | COTUIT | | | | |

| NOTES | | | | | | | | | | | | | |
|--|--|--|--|--|--|--|--|--|--|--|--|--|--|
| <p>Appraised Bldg. Value (Card) 733,300</p> <p>Appraised Xf (B) Value (Bldg) 33,900</p> <p>Appraised Ob (B) Value (Bldg) 18,600</p> <p>Appraised Land Value (Bldg) 855,400</p> <p>Special Land Value 0</p> <p>Total Appraised Parcel Value 1,641,200</p> <p>Valuation Method C</p> <p>Total Appraised Parcel Value 1,641,200</p> | | | | | | | | | | | | | |

| BUILDING PERMIT RECORD | | | | | | | | | VISIT / CHANGE HISTORY | | | | | |
|------------------------|------------|------|----------------|---------|------------|--------|------------|--------------------------------|------------------------|----|------|----|----|--------------------------|
| Permit Id | Issue Date | Type | Description | Amount | Insp Date | % Comp | Date Comp | Comments | Date | Id | Type | Is | Cd | Purpost/Result |
| 19-881 | 03-26-2019 | 835 | Sid/Wind/Roof/ | 3,500 | 06-30-2019 | 100 | 06-30-2019 | New siding on garage | 07-27-2021 | LH | 03 | | 22 | Change of Address |
| 17-713 | 03-17-2017 | 834 | Sheet Metal | 0 | 06-30-2017 | 100 | 06-30-2017 | Installing (2) hvac systems | 07-26-2021 | PK | 03 | | 16 | In Office Review |
| 16-1583 | 06-27-2016 | 804 | Addn Alt-Res | 250,000 | 02-21-2017 | 100 | 06-30-2017 | Remove Existing 1 story struct | 07-08-2020 | CK | 03 | | 16 | In Office Review |
| 200903356 | 07-20-2009 | NS | New Siding | 200 | 06-30-2010 | 100 | 06-30-2010 | RESIDE | 06-09-2020 | WD | | | | FR Field Review |
| 36557 | 02-19-1999 | NR | New Roof | 8,000 | 01-01-2000 | 100 | 01-01-2000 | STRP OLD | 03-13-2017 | SR | 01 | | | 02 Bldg Permit Completed |
| | | | | | | | | | 07-25-2016 | SR | 02 | | | 13 CALL BACK |
| | | | | | | | | | 06-14-2013 | RB | 03 | | | 16 In Office Review |

| LAND LINE VALUATION SECTION | | | | | | | | | | | | | | | | | |
|-----------------------------|----------|----------------|------|----|------------|------------|------------------------|---------|------------|-------|-------|-----------|------------------|--------------------|------------|------------|---------|
| B | Use Code | Description | Zone | LA | Land Units | Unit Price | Size Adj | AC Disc | Site Index | Cond. | Nbhd. | Nbhd. Adj | Notes | Location Adjustmen | Adj Unit P | Land Value | |
| 1 | 1010 | Single Fam M-0 | RF | 2 | 0.450 | AC | 176,344.00 | 1.95982 | 1.0000 | 5 | 1.00 | 0112 | 5.500 | | 1.0000 | 1,900,811 | 855,400 |
| Total Card Land Units | | | | | 0.45 | AC | Parcel Total Land Area | | | | | 0.45 | Total Land Value | | | 855,400 | |

| CONSTRUCTION DETAIL | | | CONSTRUCTION DETAIL (CONTINUED) | | |
|---------------------|----|----------------|---------------------------------|------|---------------------|
| Element | Cd | Description | Element | Cd | Description |
| Style | 06 | Conventional | | | |
| Model | 01 | Residential | | | |
| Grade: | B | Custom | | | |
| Stories | 2 | 2 Stories | | | |
| Exterior Wall 1 | 11 | Clapboard | | | |
| Exterior Wall 2 | 14 | Wood Shingle | | | |
| RooF Structure | 06 | Mansard | | | |
| RooF Cover | 03 | Asph/F Gls/Cmp | | | |
| Interior Wall 1 | 03 | Plastered | | | |
| Interior Wall 2 | | | | | |
| Interior Floor 1 | 12 | Hardwood | | | |
| Interior Floor 2 | | | | | |
| Heat Fuel | 03 | Gas | | | |
| Heat Type | 04 | Hot Air | | | |
| AC Type | 03 | Central | | | |
| Bedrooms | 04 | 4 Bedrooms | | | |
| Full Baths | 3 | | | | |
| Half Baths | 0 | | | | |
| Extra Fixtures | | | | | |
| Total Rooms | 7 | | | | |
| Bath Style | | | | | |
| Kitchen Style | | | | | |
| Occupancy | | | | | |
| Sewer Occupan | | | | | |
| Accessory Apt | | | | | |
| Foundation Alt | 04 | Brick Walls | | | |
| Rms Prts | | | | | |
| Bath Split | 30 | 3 Full-0 Half | | | |
| | | | CONDO DATA | | |
| | | | Parcel Id | C | Ownr 0.0 |
| | | | Adjust Type | Code | Description Factor% |
| | | | Condo Flr | | |
| | | | Condo Unit | | |
| | | | COST / MARKET VALUATION | | |
| | | | Building Value New | | 952,386 |
| | | | Year Built | | 1830 |
| | | | Effective Year Built | | 1994 |
| | | | Depreciation Code | | VG |
| | | | Remodel Rating | | |
| | | | Year Remodeled | | |
| | | | Depreciation % | | 23 |
| | | | Functional Obsol | | 0 |
| | | | External Obsol | | 0 |
| | | | Trend Factor | | 1 |
| | | | Condition | | |
| | | | Condition % | | |
| | | | Percent Good | | 77 |
| | | | RCNLD | | 733,300 |
| | | | Dep % Ovr | | |
| | | | Dep Ovr Comment | | |
| | | | Misc Imp Ovr | | |
| | | | Misc Imp Ovr Comment | | |
| | | | Cost to Cure Ovr | | |
| | | | Cost to Cure Ovr Comment | | |

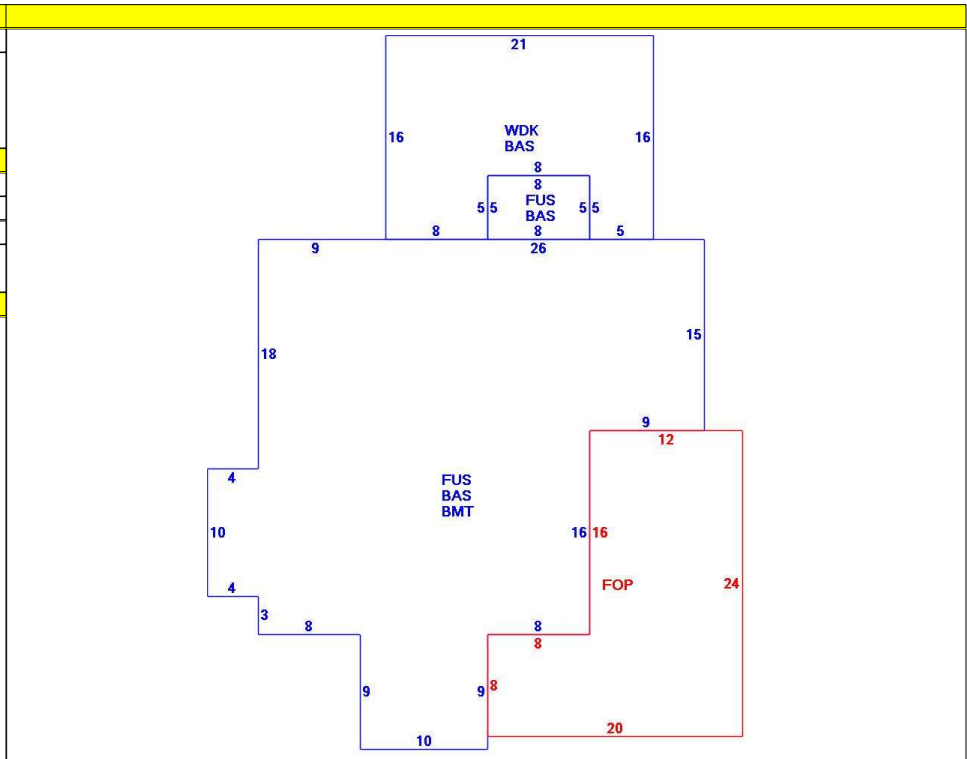

| OB - OUTBUILDING & YARD ITEMS(L) / XF - BUILDING EXTRA FEATURES(B) | | | | | | | | | | |
|--|----------------|-----|-------|------------|--------|----------|------|-------|------------|-------------|
| Code | Description | L/B | Units | Unit Price | Yr Blt | Cond. Cd | % Gd | Grade | Grade Adj. | Appr. Value |
| FGR6 | Gar w/Lft Avg | L | 528 | 60.00 | 1965 | | 41 | 00 | 1.00 | 13,000 |
| FOP | Open Porch-ro | B | 352 | 55.00 | 1989 | | 77 | | 0.00 | 10,600 |
| BMT | Basement-Unfi | B | 1,071 | 26.01 | 1989 | | 77 | | 0.00 | 21,400 |
| WDC | Wood Decking | L | 296 | 20.00 | 2016 | | 94 | | 0.00 | 5,600 |
| FPLG | Gas Fireplace- | B | 1 | 2500.00 | 1989 | | 77 | | 0.00 | 1,900 |

| BUILDING SUB-AREA SUMMARY SECTION | | | | | | |
|-----------------------------------|---------------|-------------|------------|----------|-----------|----------------|
| Code | Description | Living Area | Floor Area | Eff Area | Unit Cost | Undeprec Value |
| BAS | First Floor | 1,407 | 1,407 | 1,407 | 378.23 | 532,171 |
| BMT | Basement Area | 0 | 1,071 | 0 | 0.00 | 0 |
| FOP | Open Porch | 0 | 352 | 0 | 0.00 | 0 |
| FUS | Upper Story | 1,111 | 1,111 | 1,111 | 378.23 | 420,215 |
| WDK | Wood Deck | 0 | 296 | 0 | 0.00 | 0 |
| Ttl Gross Liv / Lease Area | | 2,518 | 4,237 | 2,518 | | 952,386 |

