

CURRENT OWNER		TOPO	UTILITIES	STRT / ROAD	LOCATION	CURRENT ASSESSMENT			
FALCONE, LOUIS T & BENDER, CAR						Description	Code	Assessed	Assessed
134 WALWORTH STREET					4 Hyannis CU	RESIDNTL	1020	172,200	172,200
BOSTON MA 02131		<b>SUPPLEMENTAL DATA</b>							
		Alt Prcl ID		Plan Ref.					
		Split Zonin		Land Ct# 36029-C-1 LOT 2					
		BID Parcel		#SR					
		ResExpt Q		Life Estate					
		#DL 1 UNIT M5		PP STATU					
		#DL 2 BLDG 11							
		GIS ID F_987476_2696069		Assoc Pid#					
						Total		172,200	172,200

801  
 FY2025  
 BARNSTABLE, MA

**VISION**

RECORD OF OWNERSHIP		BK-VOL/PAGE	SALE DATE	Q/U	V/I	SALE PRICE	VC	PREVIOUS ASSESSMENTS (HISTORY)								
FALCONE, LOUIS T & BENDER, CAROL V		C144-0	07-29-2022	Q	I	176,000	00	Year	Code	Assessed	Year	Code	Assessed V	Year	Code	Assessed
GORECKI, JON M		C144-0	10-21-2019	Q	I	103,000	00	2025	1020	172,200	2024	1020	148,900	2023	1020	163,600
DWYER, MARK CLIFFORD		C144-0	10-19-2012	U	I	1	1A									
TOSCANO, ELIZABETH M & GULDEN, LINDA JILL		C144-0	04-11-2007	U	I	1	1A									
		C144-0	10-31-2006	U	I	100,000	1									
								Total		172,200	Total		148,900	Total		163,600

EXEMPTIONS			OTHER ASSESSMENTS					
Year	Code	Description	Amount	Code	Description	Number	Amount	Comm Int
		Total	0.00					

This signature acknowledges a visit by a Data Collector or Assessor

ASSESSING NEIGHBORHOOD				
Nbhd	Nbhd Name	B	Tracing	Batch
0001				HYAN

NOTES			

APPRAISED VALUE SUMMARY			
Appraised Bldg. Value (Card)			170,300
Appraised Xf (B) Value (Bldg)			0
Appraised Ob (B) Value (Bldg)			1,900
Appraised Land Value (Bldg)			0
Special Land Value			0
Total Appraised Parcel Value			172,200
Valuation Method			C
Total Appraised Parcel Value			172,200

BUILDING PERMIT RECORD						VISIT / CHANGE HISTORY								
Permit Id	Issue Date	Type	Description	Amount	Insp Date	% Comp	Date Comp	Comments	Date	Id	Type	Is	Cd	Purpost/Result
									05-10-2023	TR	02		20	Sale Review
									05-08-2020	WD			FR	Field Review
									03-03-2020	SAF			20	Sale Review
									04-10-2019	SR	02		03	Cycl Insp Comp
									03-27-2012	DR	03		16	In Office Review

LAND LINE VALUATION SECTION																		
B	Use Code	Description	Zone	Dist	Land Type	Land Units	Unit Price	Size Adj	Site Index	Cond.	Nbhd.	Nbhd. Adj	Notes	Location Adjustmen	Adj Unit P	Land Value		
1	102U	Condominium M	RB	4	Hyannis	0 SF	0.00	1.00000	5	1.00	0001	1.000		0.0000	0	0		
Total Card Land Units						0 SF	Parcel Total Land Area						0.00	Total Land Value				0

CONSTRUCTION DETAIL			CONSTRUCTION DETAIL (CONTINUED)		
Element	Cd	Description	Element	Cd	Description
Style	55	Condominium			
Model	05	Res Condo			
Grade	C	Average			
Stories	1	1 Story			
Occupancy	0				
Interior Wall 1	05	Drywall			
Interior Wall 2					
Interior Floor 1	14	Carpet			
Interior Floor 2					
Heat Fuel	04	Electric			
Heat Type	05	Hot Water			
AC Type	01	None			
Bedrooms	01	1 Bedroom			
Full Baths	1	1 Full			
Half Baths	0				
Extra Fixtures					
Total Rooms	2	2 Rooms			
Bath Style					
Kitchen Style					
Master Deed L	290				
Bath Split	10	1 Full-0 Half			
Foundation	03	Conc. Slab			
AC Type Alt					
Sewer Occupan					
<b>CONDO DATA</b>					
Parcel Id	104214	C 0110	Ownr	1.4	
	CAPTAIN GOSNOL	B 1	S 1		
Adjust Type	Code	Description	Factor%		
Condo Flr			100		
Condo Unit	MKT0	MKT0	100		
<b>COST / MARKET VALUATION</b>					
Building Value New		210,239			
Year Built		1951			
Effective Year Built		1999			
Depreciation Code		G			
Remodel Rating					
Year Remodeled		19			
Depreciation %		0			
Functional Obsol		0			
External Obsol		0			
Trend Factor		1			
Condition					
Condition %		81			
Percent Good		170,300			
Cns Sect Rcnd					
Dep % Ovr					
Dep Ovr Comment					
Misc Imp Ovr					
Misc Imp Ovr Comment					
Cost to Cure Ovr					
Cost to Cure Ovr Comment					

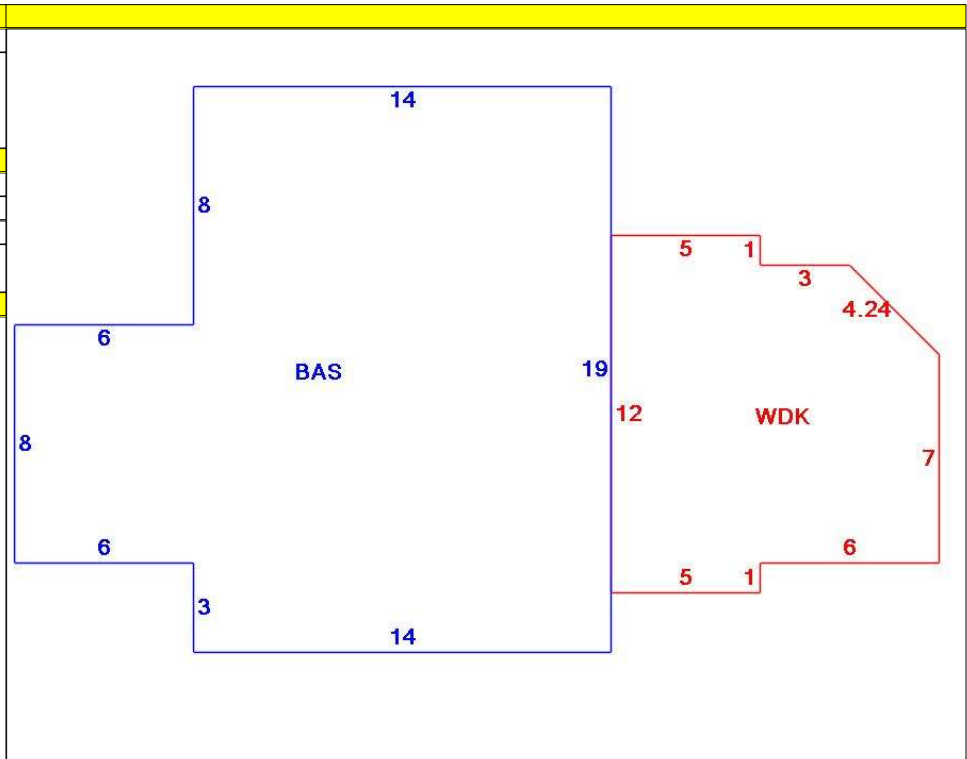

OB - OUTBUILDING & YARD ITEMS(L) / XF - BUILDING EXTRA FEATURES(B)										
Code	Description	L/B	Units	Unit Price	Yr Blt	Cond. Cd	% Gd	Grade	Grade Adj.	Appr. Value
WDC	Wood Decking	L	116	20.00	1994		50		0.00	1,900

BUILDING SUB-AREA SUMMARY SECTION						
Code	Description	Living Area	Floor Area	Eff Area	Unit Cost	Undeprec Value
BAS	First Floor	314	314	314	669.55	210,239
WDC	Wood Deck	0	116	0	0.00	0
Ttl Gross Liv / Lease Area		314	430	314		210,239

