

CURRENT OWNER		TOPO	UTILITIES	STRT / ROAD	LOCATION	CURRENT ASSESSMENT				801 FY2025 BARNSTABLE, MA  <b>VISION</b>
BERMUDEZ, MARINA ALAS  396 BEARSES WAY  HYANNIS MA 02601-2764	1 Level	6 Septic	1 Paved			Description	Code	Assessed	Assessed	
		4 Gas				RESIDNTL	1010	282,500	282,500	
		2 Public Water			4	RES LAND	1010	135,300	135,300	
<b>SUPPLEMENTAL DATA</b>						Total				417,800
Alt Prcl ID		Split Zonin		Plan Ref.						
BID Parcel		ResExpt Q		Land Ct# 21173-F						
#DL 1 LOT 38		#DL 2		#SR						
GIS ID F_985437_2704211		Assoc Pid#		Life Estate						
				PP STATU						

RECORD OF OWNERSHIP		BK-VOL/PAGE	SALE DATE	Q/U	V/I	SALE PRIC	VC	PREVIOUS ASSESSMENTS (HISTORY)								
BERMUDEZ, MARINA ALAS	C222230	0	03-31-2020	Q	I	290,000	00	Year	Code	Assessed	Year	Code	Assessed	Year	Code	Assessed
CURLEY, JAY J & ANETTE K TRS	C192786	0	10-28-2010	U	I	1	1F	2025	1010	282,500	2024	1010	280,300	2023	1010	242,300
CURLEY, JAY J & ANETTE K	C116736	0	02-02-1989	Q	I	85,000	U		1010	135,300		1010	135,300		1010	129,800
DECRISTOFARO, NANCY	#D47764	0	06-15-1988	U	I	1	A									
DECRISTOFARO, JAMES R & NANCY	C72843	0	12-29-1977	U		0										
Total								417,800	Total		415,600	Total		372,100		

EXEMPTIONS			OTHER ASSESSMENTS					This signature acknowledges a visit by a Data Collector or Assessor											
Year	Code	Description	Amount	Code	Description	Number	Amount	Comm	Int										
Total			0.00																

ASSESSING NEIGHBORHOOD						APPRAISED VALUE SUMMARY			
Nbhd	Nbhd Name	B	Tracing	Batch					
0104				HYAN	Appraised Bldg. Value (Card)	241,900			
					Appraised Xf (B) Value (Bldg)	37,300			
					Appraised Ob (B) Value (Bldg)	3,300			
					Appraised Land Value (Bldg)	135,300			
					Special Land Value	0			
					Total Appraised Parcel Value	417,800			
					Valuation Method	C			
					Total Appraised Parcel Value	417,800			

NOTES											VISIT / CHANGE HISTORY					
Permit Id	Issue Date	Type	Description	Amount	Insp Date	% Comp	Date Comp	Comments			Date	Id	Type	Is	Cd	Purpost/Result
											05-05-2020	WD			FR	Field Review
											10-17-2017	SR	02		03	Cycl Insp Comp
											05-13-2003	PT	02		01	Meas/Est
											03-01-2001	SM	01		00	Meas/Listed-Interior Acces
											08-15-1987	ML	01		00	Meas/Listed-Interior Acces

LAND LINE VALUATION SECTION																	
B	Use Code	Description	Zone	LA	Land Units	Unit Price	Size Adj	AC Disc	Site Index	Cond.	Nbhd.	Nbhd. Adj	Notes	Location Adjustmen	Adj Unit P	Land Value	
1	1010	Single Fam M-0	RB	4	0.290	AC	176,344.00	2.93869	1.0000	5	1.00	0104	0.900		1.0000	466,394.6	135,300
Total Card Land Units					0.29	AC	Parcel Total Land Area					0.29	Total Land Value			135,300	

CONSTRUCTION DETAIL			CONSTRUCTION DETAIL (CONTINUED)		
Element	Cd	Description	Element	Cd	Description
Style	01	Ranch			
Model	01	Residential			
Grade:	C-	Average Minus			
Stories	1	1 Story			
Exterior Wall 1	14	Wood Shingle			
Exterior Wall 2	11	Clapboard			
RooF Structure	03	Gable/Hip			
RooF Cover	03	Asph/F Gls/Cmp			
Interior Wall 1	05	Drywall			
Interior Wall 2					
Interior Floor 1	14	Carpet			
Interior Floor 2	12	Hardwood			
Heat Fuel	03	Gas			
Heat Type	05	Hot Water			
AC Type	01	None			
Bedrooms	03	3 Bedrooms			
Full Baths	2				
Half Baths	0				
Extra Fixtures					
Total Rooms	5	5 Rooms			
Bath Style					
Kitchen Style					
Occupancy					
Sewer Occupan					
Accessory Apt					
Foundation Alt	01	Poured Conc.			
Rms Prts					
Bath Split	20	2 Full-0 Half			
			<b>CONDO DATA</b>		
Parcel Id			C	Owne	0.0
Adjust Type		Code	Description	Factor%	
Condo Flr					
Condo Unit					
<b>COST / MARKET VALUATION</b>					
Building Value New			310,180		
Year Built			1972		
Effective Year Built			1996		
Depreciation Code			A		
Remodel Rating					
Year Remodeled					
Depreciation %			22		
Functional Obsol			0		
External Obsol			0		
Trend Factor			1		
Condition					
Condition %					
Percent Good			78		
RCNLD			241,900		
Dep % Ovr					
Dep Ovr Comment					
Misc Imp Ovr					
Misc Imp Ovr Comment					
Cost to Cure Ovr					
Cost to Cure Ovr Comment					

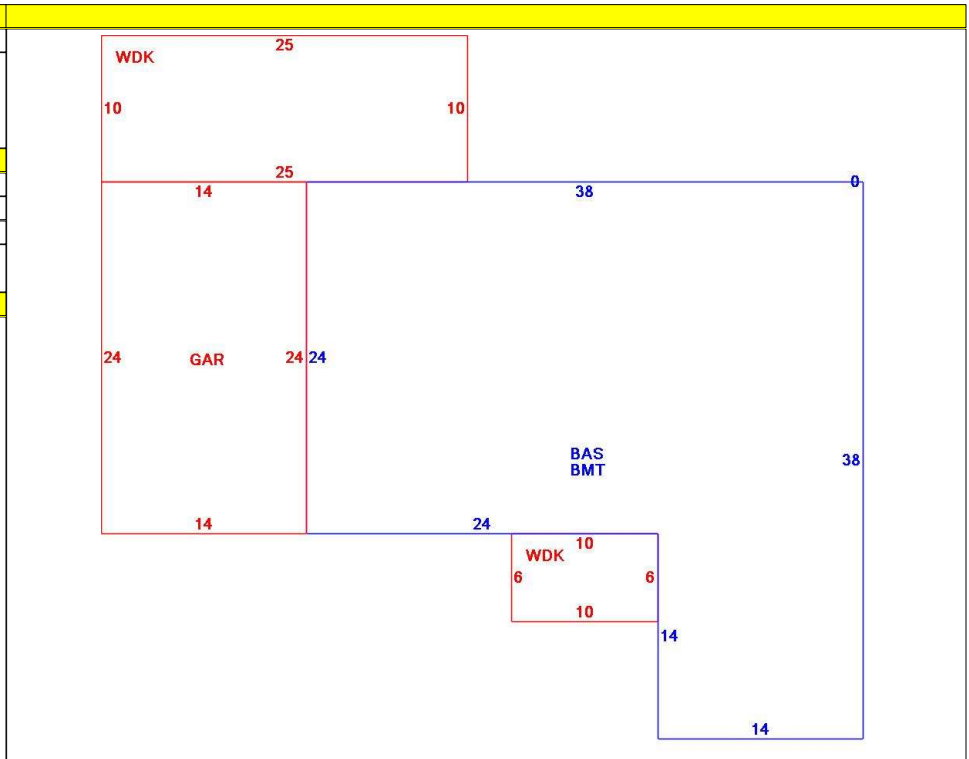

OB - OUTBUILDING & YARD ITEMS(L) / XF - BUILDING EXTRA FEATURES(B)										
Code	Description	L/B	Units	Unit Price	Yr Blt	Cond. Cd	% Gd	Grade	Grade Adj.	Appr. Value
FPL1	Fireplace 1 sto	B	1	5000.00	1994		78		0.00	3,900
WDC	Wood Decking	L	310	20.00	1996		54		0.00	3,300
GAR	Attached Gara	B	336	40.00	1994		78		0.00	11,200
BMT	Basement-Unfi	B	1,108	26.01	1994		78		0.00	22,200

BUILDING SUB-AREA SUMMARY SECTION						
Code	Description	Living Area	Floor Area	Eff Area	Unit Cost	Undeprec Value
BAS	First Floor	1,108	1,108	1,108	279.95	310,180
BMT	Basement Area	0	1,108	0	0.00	0
GAR	Attached Garage	0	336	0	0.00	0
WDK	Wood Deck	0	310	0	0.00	0
Ttl Gross Liv / Lease Area		1,108	2,862	1,108		310,180

