

CURRENT OWNER				TOPO	UTILITIES	STRT / ROAD	LOCATION	CURRENT ASSESSMENT				
KING, ARTHUR G, JR 25B CASTLE HILL ROAD AGAWAM MA 01001				1	1	1		Description	Code	Assessed	Assessed	801 FY2025 BARNSTABLE, MA VISION
				Level	All Public	Paved		RESIDNTL	1010	283,800	283,800	
			4	RES LAND	1010	123,400	123,400					
SUPPLEMENTAL DATA								Total	407,200	407,200		
Alt Prcl ID				Split Zonin		Plan Ref. 37/77						
BID Parcel				ResExpt Q		Land Ct#						
#DL 1				LOT 15 &		#SR						
#DL 2				PT16		Life Estate						
GIS ID				F_988904_2703429		PP STATU						
						Assoc Pid#						

RECORD OF OWNERSHIP				BK-VOL/PAGE	SALE DATE	Q/U	V/I	SALE PRIC	VC	PREVIOUS ASSESSMENTS (HISTORY)						
KING, ARTHUR G, JR				23077	0153	07-31-2008	U	I	160,000	1	Year	Code	Assessed	Year	Code	Assessed
JORGE, JACY MOURA				19704	0205	04-08-2005	Q	I	260,000	00	2025	1010	283,800	2024	1010	277,300
PETERSON, MARTHA H ESTATE OF				3037	0220	12-28-1979	Q		36,200	U		1010	123,400	2023	1010	235,400
											Total	407,200	Total	400,700	Total	353,800

EXEMPTIONS				OTHER ASSESSMENTS			
Year	Code	Description	Amount	Code	Description	Number	Amount
Total			0.00				

ASSESSING NEIGHBORHOOD			
Nbhd	Nbhd Name	B	Tracing
0104			Batch HYAN

NOTES			
This signature acknowledges a visit by a Data Collector or Assessor			
APPRAISED VALUE SUMMARY			
Appraised Bldg. Value (Card)			270,100
Appraised Xf (B) Value (Bldg)			11,700
Appraised Ob (B) Value (Bldg)			2,000
Appraised Land Value (Bldg)			123,400
Special Land Value			0
Total Appraised Parcel Value			407,200
Valuation Method			C
Total Appraised Parcel Value			407,200

BUILDING PERMIT RECORD									VISIT / CHANGE HISTORY					
Permit Id	Issue Date	Type	Description	Amount	Insp Date	% Comp	Date Comp	Comments	Date	Id	Type	Is	Cd	Purpost/Result
16-594	03-14-2016	835	Sid/Wind/Roof/	11,200		100		re-side	05-12-2020	WD			FR	Field Review
200903333	07-20-2009	OB	Out Building	0	12-14-2009	100	06-30-2010	6X8 SHED ON BLOCKS	04-03-2019	CK	22		22	Change of Address
200806343	11-12-2008	NR	New Roof	2,800	12-14-2009	100	06-30-2010	STRIP&REROOF	11-06-2017	SR	02		03	Cycl Insp Comp
B23154	05-01-1981	AD	Addition	0	01-15-1982	100		HY ADD'N	06-08-2010	TP	03		16	In Office Review
									12-14-2009	MK	02		02	Bldg Permit Completed
									01-25-2006	PT	02		01	Meas/Est
									03-26-2001	PT	01		00	Meas/Listed-Interior Acces

LAND LINE VALUATION SECTION																	
B	Use Code	Description	Zone	LA	Land Units	Unit Price	Size Adj	AC Disc	Site Index	Cond.	Nbhd.	Nbhd. Adj	Notes	Location Adjustmen	Adj Unit P	Land Value	
1	1010	Single Fam M-0	DN	4	0.150	AC	176,344.00	5.18399	1.0000	5	1.00	0104	0.900		1.0000	822,750.5	123,400
Total Card Land Units					0.15	AC	Parcel Total Land Area					0.15	Total Land Value			123,400	

CONSTRUCTION DETAIL			CONSTRUCTION DETAIL (CONTINUED)		
Element	Cd	Description	Element	Cd	Description
Style	01	Ranch			
Model	01	Residential			
Grade:	C-	Average Minus			
Stories	1	1 Story			
Exterior Wall 1	14	Wood Shingle			
Exterior Wall 2					
Roof Structure	03	Gable/Hip			
Roof Cover	03	Asph/F Gls/Cmp			
Interior Wall 1	05	Drywall			
Interior Wall 2					
Interior Floor 1	12	Hardwood			
Interior Floor 2					
Heat Fuel	02	Oil			
Heat Type	04	Hot Air			
AC Type	03	Central			
Bedrooms	03	3 Bedrooms			
Full Baths	2				
Half Baths	0				
Extra Fixtures					
Total Rooms	6	6 Rooms			
Bath Style					
Kitchen Style					
Occupancy					
Sewer Occupan					
Accessory Apt					
Foundation Alt	09	Blk/Pour Ftgs			
Rms Prts					
Bath Split	20	2 Full-0 Half			

CONDO DATA				
Parcel Id		C	Owne	0.0
Adjust Type	Code	Description	Factor%	
Condo Flr				
Condo Unit				

COST / MARKET VALUATION	
Building Value New	391,431
Year Built	1930
Effective Year Built	1984
Depreciation Code	A
Remodel Rating	
Year Remodeled	
Depreciation %	31
Functional Obsol	0
External Obsol	0
Trend Factor	1
Condition	
Condition %	
Percent Good	69
RCNLD	270,100
Dep % Ovr	
Dep Ovr Comment	
Misc Imp Ovr	
Misc Imp Ovr Comment	
Cost to Cure Ovr	
Cost to Cure Ovr Comment	

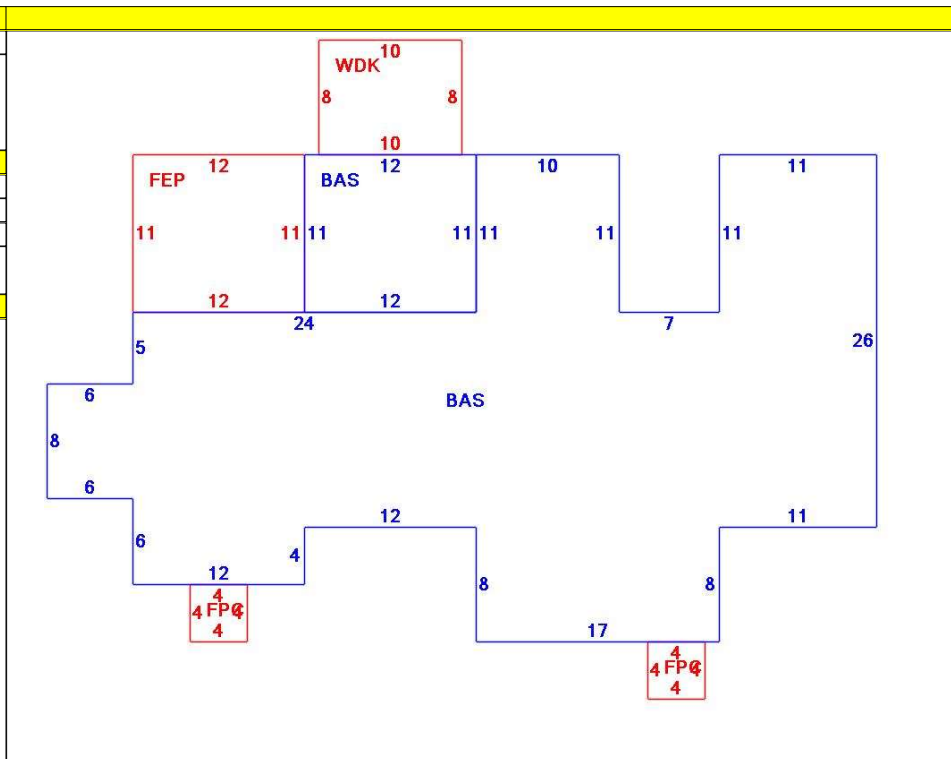

OB - OUTBUILDING & YARD ITEMS(L) / XF - BUILDING EXTRA FEATURES(B)										
Code	Description	L/B	Units	Unit Price	Yr Blt	Cond. Cd	% Gd	Grade	Grade Adj.	Appr. Value
FPL1	Fireplace 1 sto	B	1	5000.00	1979		69		0.00	3,500
WDC	Wood Decking	L	80	20.00	1986		34		0.00	1,200
FOPC	Open Prch-roo	B	32	55.00	1979		69		0.00	1,400
FEP	Enclosed porc	B	132	70.00	1979		69		0.00	6,800
SHED	Shed	L	48	18.00	2017		96		0.00	800

BUILDING SUB-AREA SUMMARY SECTION						
Code	Description	Living Area	Floor Area	Eff Area	Unit Cost	Undeprec Value
BAS	First Floor	1,375	1,375	1,375	284.68	391,431
FEP	Enclosed Porch	0	132	0	0.00	0
FPC	Open Porch Conc. Floor	0	32	0	0.00	0
WDK	Wood Deck	0	80	0	0.00	0
Ttl Gross Liv / Lease Area		1,375	1,619	1,375		391,431

