

| CURRENT OWNER                 |  | TOPO                     | UTILITIES | STRT / ROAD       | LOCATION | CURRENT ASSESSMENT |      |           |           |                                 |
|-------------------------------|--|--------------------------|-----------|-------------------|----------|--------------------|------|-----------|-----------|---------------------------------|
| FRIEDENSOHN, PETER&HOPKINS, P |  |                          |           |                   |          | Description        | Code | Assessed  | Assessed  | 801<br>FY2025<br>BARNSTABLE, MA |
| 2 BATTERY WHARF, UNIT 2042    |  |                          |           |                   | 7        | RESIDENTL          | 1010 | 1,005,300 | 1,005,300 |                                 |
| BOSTON MA 02109               |  | <b>SUPPLEMENTAL DATA</b> |           |                   |          | RES LAND           | 1010 | 1,729,900 | 1,729,900 | <b>VISION</b>                   |
|                               |  | Alt Prcl ID              |           | Plan Ref. 21/89   |          |                    |      |           |           |                                 |
|                               |  | Split Zonin              |           | Land Ct# 15354-77 |          |                    |      |           |           |                                 |
|                               |  | BID Parcel               |           | #SR               |          |                    |      |           |           |                                 |
|                               |  | ResExpt Q                |           | Life Estate       |          |                    |      |           |           |                                 |
|                               |  | #DL 1 LOTS 2 & 70        |           | PP STATU          |          |                    |      |           |           |                                 |
|                               |  | #DL 2                    |           |                   |          |                    |      |           |           |                                 |
|                               |  | GIS ID F_951790_2687142  |           | Assoc Pid#        |          |                    |      |           |           |                                 |
|                               |  |                          |           |                   |          | Total              |      | 2,735,200 | 2,735,200 |                                 |

| RECORD OF OWNERSHIP               |  | BK-VOL/PAGE | SALE DATE | Q/U        | V/I | SALE PRIC | VC        | PREVIOUS ASSESSMENTS (HISTORY) |       |      |           |       |      |           |
|-----------------------------------|--|-------------|-----------|------------|-----|-----------|-----------|--------------------------------|-------|------|-----------|-------|------|-----------|
| FRIEDENSOHN, PETER&HOPKINS, PAT   |  | C195984     | 0         | 12-28-2011 | U   | I         | 1         | 1F                             | Year  | Code | Assessed  | Year  | Code | Assessed  |
| FRIEDENSOHN, PETER&HOPKINS, PAT   |  | C191553     | 0         | 06-01-2010 | U   | I         | 1         | 1F                             | 2025  | 1010 | 1,005,300 | 2024  | 1010 | 955,900   |
| FRIEDENSOHN, PETER & HOPKINS, PAT |  | C190297     | 0         | 12-15-2009 | Q   | I         | 1,300,000 | 00                             |       | 1010 | 1,729,900 | 2023  | 1010 | 1,363,400 |
| SARNEY, ELAINE TR                 |  | 23293       | 0086      | 12-02-2008 | U   | I         | 0         | 1                              |       |      |           |       |      |           |
| SARNEY, GEORGE W TR               |  | 14537       | 0090      | 12-06-2001 | U   | I         | 1         | 1F                             |       |      |           |       |      |           |
|                                   |  |             |           |            |     | Total     |           | 2,735,200                      | Total |      | 2,685,800 | Total |      | 2,222,800 |

| EXEMPTIONS |      |             | OTHER ASSESSMENTS |      |             |        |        |          |
|------------|------|-------------|-------------------|------|-------------|--------|--------|----------|
| Year       | Code | Description | Amount            | Code | Description | Number | Amount | Comm Int |
|            |      |             |                   |      |             |        |        |          |
| Total      |      |             | 0.00              |      |             |        |        |          |

| ASSESSING NEIGHBORHOOD |           |
|------------------------|-----------|
| Nbhd                   | Nbhd Name |
| 0117                   | B         |
|                        | Tracing   |
|                        | Batch     |
|                        | OSTVIL    |

| NOTES                                                               |           |
|---------------------------------------------------------------------|-----------|
| This signature acknowledges a visit by a Data Collector or Assessor |           |
| <b>APPRAISED VALUE SUMMARY</b>                                      |           |
| Appraised Bldg. Value (Card)                                        | 821,800   |
| Appraised Xf (B) Value (Bldg)                                       | 64,800    |
| Appraised Ob (B) Value (Bldg)                                       | 118,700   |
| Appraised Land Value (Bldg)                                         | 1,729,900 |
| Special Land Value                                                  | 0         |
| Total Appraised Parcel Value                                        | 2,735,200 |
| Valuation Method                                                    | C         |
| Total Appraised Parcel Value                                        | 2,735,200 |

| BUILDING PERMIT RECORD |            |      |                  |         |            |        |            | VISIT / CHANGE HISTORY          |            |    |      |    |    |                          |
|------------------------|------------|------|------------------|---------|------------|--------|------------|---------------------------------|------------|----|------|----|----|--------------------------|
| Permit Id              | Issue Date | Type | Description      | Amount  | Insp Date  | % Comp | Date Comp  | Comments                        | Date       | Id | Type | Is | Cd | Purpost/Result           |
| EXPR-22-1              | 02-08-2022 | 835  | Sid/Wind/Roof/   | 15,000  |            | 100    |            | Replacing 2 triple mulled wind  | 06-12-2020 | WD |      |    | 25 | NO TRESPASSING           |
| 18-3980                | 12-05-2018 | 880  | Alt-Int work-Res | 3,000   | 05-06-2019 | 100    | 06-30-2019 | Water Damage From Re-Roof       | 06-05-2019 | SR | 02   |    | 02 | Bldg Permit Completed    |
| 18-3429                | 11-01-2018 | 839  | Solar Panel-Re   | 51,782  | 05-06-2019 | 100    | 06-30-2019 | Install a roof mounted solar PV | 06-06-2016 | SR | 02   |    | 03 | Cycl Insp Comp           |
| 201107286              | 02-01-2012 | AD   | Addition         | 150,000 | 02-13-2013 | 100    | 06-30-2013 | POOL HSE-1 OPEN RM, .5 B        | 05-15-2015 | JR | 03   |    | 03 | Cycl Insp Comp           |
| 201105886              | 11-08-2011 | SP   | Swimming Pool    | 32,000  | 02-13-2013 | 100    | 06-30-2013 | 18X50 GUNITE POOL W 5' N        | 04-05-2013 | RB | 03   |    | 02 | Bldg Permit Completed    |
| 64255                  | 09-24-2002 | NR   | New Roof         |         | 04-15-2003 | 100    | 01-01-2003 | REROOF STRIPPING OLD            | 05-25-2006 | PT | 02   |    | 01 | Meas/Est                 |
| 42720                  | 11-30-1999 | AD   | Addition         | 50,000  | 01-01-2000 | 100    | 12-31-2000 | ATTACHED GARAGE W/ BED          | 04-15-2003 | MF | 04   |    | 44 | Drive by inspection only |

| LAND LINE VALUATION SECTION |          |                |      |    |            |            |                        |         |            |       |       |           |                  |                    |            |            |           |
|-----------------------------|----------|----------------|------|----|------------|------------|------------------------|---------|------------|-------|-------|-----------|------------------|--------------------|------------|------------|-----------|
| B                           | Use Code | Description    | Zone | LA | Land Units | Unit Price | Size Adj               | AC Disc | Site Index | Cond. | Nbhd. | Nbhd. Adj | Notes            | Location Adjustmen | Adj Unit P | Land Value |           |
| 1                           | 1010     | Single Fam M-0 | RF-1 | 3  | 1.000      | AC         | 176,344.00             | 1.00000 | 1.0000     | 5     | 1.00  | 0117      | 9.700            |                    | 1.0000     | 1,710,536  | 1,710,500 |
| 1                           | 1010     | Single Fam M-0 | RF-1 | 3  | 0.140      | AC         | 14,250.00              | 1.00000 | 1.0000     | 0     | 1.00  | 0117      | 9.700            |                    | 1.0000     | 138,225    | 19,400    |
| Total Card Land Units       |          |                |      |    | 1.14       | AC         | Parcel Total Land Area |         |            |       |       | 1.14      | Total Land Value |                    |            | 1,729,900  |           |

| CONSTRUCTION DETAIL |      |               | CONSTRUCTION DETAIL (CONTINUED)      |    |             |
|---------------------|------|---------------|--------------------------------------|----|-------------|
| Element             | Cd   | Description   | Element                              | Cd | Description |
| Style               | 04   | Cape Cod      |                                      |    |             |
| Model               | 01   | Residential   |                                      |    |             |
| Grade:              | C+   | Average Plus  |                                      |    |             |
| Stories             | 1.75 | 1 3/4 Stories |                                      |    |             |
| Exterior Wall 1     | 14   | Wood Shingle  |                                      |    |             |
| Exterior Wall 2     | 19   | Brick Veneer  |                                      |    |             |
| Roof Structure      | 03   | Gable/Hip     |                                      |    |             |
| Roof Cover          | 10   | Wood Shingle  |                                      |    |             |
| Interior Wall 1     | 05   | Drywall       |                                      |    |             |
| Interior Wall 2     |      |               |                                      |    |             |
| Interior Floor 1    | 12   | Hardwood      |                                      |    |             |
| Interior Floor 2    | 14   | Carpet        |                                      |    |             |
| Heat Fuel           | 02   | Oil           |                                      |    |             |
| Heat Type           | 04   | Hot Air       |                                      |    |             |
| AC Type             | 03   | Central       |                                      |    |             |
| Bedrooms            | 05   | 5 Bedrooms    |                                      |    |             |
| Full Baths          | 4    |               |                                      |    |             |
| Half Baths          | 0    |               |                                      |    |             |
| Extra Fixtures      |      |               |                                      |    |             |
| Total Rooms         | 9    | 9 Rooms       |                                      |    |             |
| Bath Style          |      |               |                                      |    |             |
| Kitchen Style       |      |               |                                      |    |             |
| Occupancy           |      |               |                                      |    |             |
| Sewer Occupan       |      |               |                                      |    |             |
| Accessory Apt       |      |               |                                      |    |             |
| Foundation Alt      | 01   | Poured Conc.  |                                      |    |             |
| Rms Prts            |      |               |                                      |    |             |
| Bath Split          | 40   | 4 Full-0 Half |                                      |    |             |
|                     |      |               | <b>CONDO DATA</b>                    |    |             |
|                     |      |               | Parcel Id                            | C  | Owne 0.0    |
|                     |      |               | Adjust Type Code Description Factor% |    |             |
|                     |      |               | Condo Flr                            |    |             |
|                     |      |               | Condo Unit                           |    |             |
|                     |      |               | <b>COST / MARKET VALUATION</b>       |    |             |
|                     |      |               | Building Value New                   |    | 1,110,517   |
|                     |      |               | Year Built                           |    | 1960        |
|                     |      |               | Effective Year Built                 |    | 1990        |
|                     |      |               | Depreciation Code                    |    | A           |
|                     |      |               | Remodel Rating                       |    |             |
|                     |      |               | Year Remodeled                       |    |             |
|                     |      |               | Depreciation %                       |    | 26          |
|                     |      |               | Functional Obsol                     |    | 0           |
|                     |      |               | External Obsol                       |    | 0           |
|                     |      |               | Trend Factor                         |    | 1           |
|                     |      |               | Condition                            |    |             |
|                     |      |               | Condition %                          |    |             |
|                     |      |               | Percent Good                         |    | 74          |
|                     |      |               | RCNLD                                |    | 821,800     |
|                     |      |               | Dep % Ovr                            |    |             |
|                     |      |               | Dep Ovr Comment                      |    |             |
|                     |      |               | Misc Imp Ovr                         |    |             |
|                     |      |               | Misc Imp Ovr Comment                 |    |             |
|                     |      |               | Cost to Cure Ovr                     |    |             |
|                     |      |               | Cost to Cure Ovr Comment             |    |             |

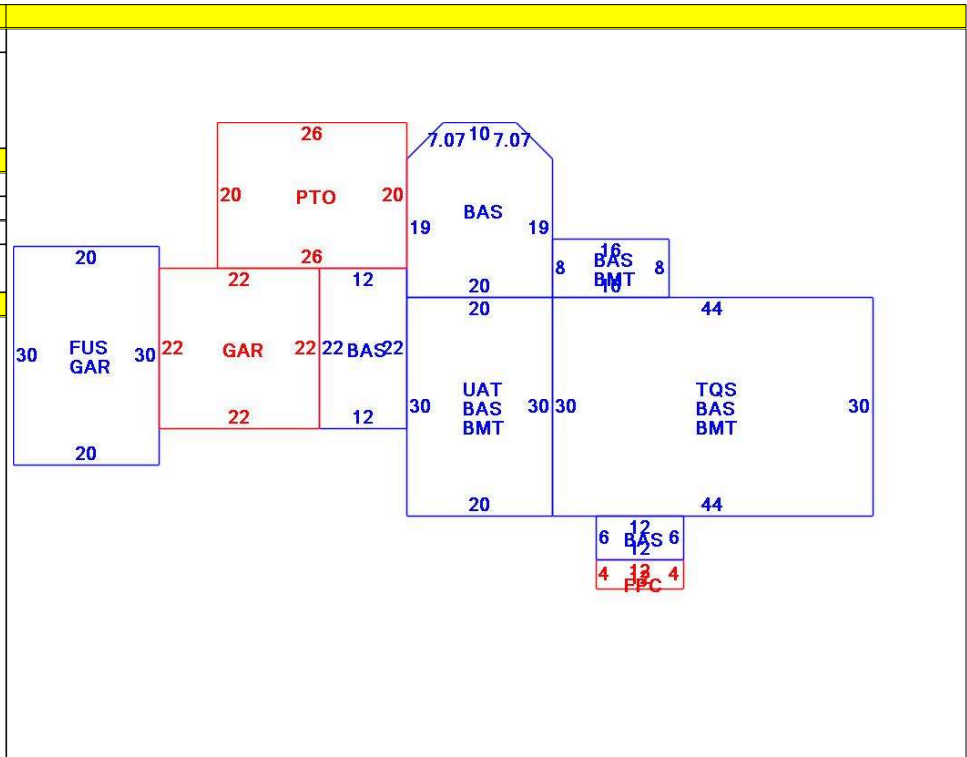

| OB - OUTBUILDING & YARD ITEMS(L) / XF - BUILDING EXTRA FEATURES(B) |                 |     |       |            |        |          |      |       |            |             |
|--------------------------------------------------------------------|-----------------|-----|-------|------------|--------|----------|------|-------|------------|-------------|
| Code                                                               | Description     | L/B | Units | Unit Price | Yr Blt | Cond. Cd | % Gd | Grade | Grade Adj. | Appr. Value |
| FPL2                                                               | Fireplace 1.5 s | B   | 1     | 6000.00    | 1988   |          | 74   |       | 0.00       | 4,400       |
| SHED                                                               | Shed            | L   | 160   | 18.00      | 1985   |          | 32   |       | 0.00       | 900         |
| PATC                                                               | Conc Pavers     | L   | 520   | 15.46      | 1977   |          | 58   |       | 0.00       | 4,500       |
| GAR                                                                | Attached Gara   | B   | 1,084 | 40.00      | 1988   |          | 74   |       | 0.00       | 24,500      |
| BMT                                                                | Basement-Unfi   | B   | 2,048 | 26.01      | 1988   |          | 74   |       | 0.00       | 33,800      |
| SPL3                                                               | Pool Gunite     | L   | 720   | 75.00      | 2011   |          | 74   | 00    | 1.00       | 40,900      |
| PAT1                                                               | Patio- Average  | L   | 1,464 | 5.89       | 2011   |          | 92   |       | 0.00       | 6,800       |
| FNP4                                                               | FENCE META      | L   | 400   | 16.76      | 2011   |          | 74   | C     | 1.00       | 5,000       |
| FNG1                                                               | Gate 4'x3'w     | L   | 3     | 301.53     | 2011   |          | 74   | C     | 1.00       | 700         |
| PHS2                                                               | Pool Hs/Avg.pl  | L   | 528   | 120.00     | 2011   |          | 87   | C     | 1.00       | 55,100      |

| BUILDING SUB-AREA SUMMARY SECTION |                        |             |            |          |           |                |
|-----------------------------------|------------------------|-------------|------------|----------|-----------|----------------|
| Code                              | Description            | Living Area | Floor Area | Eff Area | Unit Cost | Undeprec Value |
| BAS                               | First Floor            | 2,839       | 2,839      | 2,839    | 254.88    | 723,607        |
| BMT                               | Basement Area          | 0           | 2,048      | 0        | 0.00      | 0              |
| FPC                               | Open Porch Conc. Floor | 0           | 48         | 0        | 0.00      | 0              |
| FUS                               | Upper Story            | 600         | 600        | 600      | 254.88    | 152,929        |
| GAR                               | Attached Garage        | 0           | 1,084      | 0        | 0.00      | 0              |
| PTO                               | Patio                  | 0           | 520        | 0        | 0.00      | 0              |
| TQS                               | Three Quarter Story    | 858         | 1,320      | 858      | 165.67    | 218,688        |
| UAT                               | Attic, Unfinished      | 0           | 600        | 60       | 25.49     | 15,293         |
| Ttl Gross Liv / Lease Area        |                        | 4,297       | 9,059      | 4,357    |           | 1,110,517      |



| CURRENT OWNER                                                                          |  |  | TOPO        | UTILITIES        | STRT / ROAD | LOCATION | CURRENT ASSESSMENT |      |           |           |                                                          |
|----------------------------------------------------------------------------------------|--|--|-------------|------------------|-------------|----------|--------------------|------|-----------|-----------|----------------------------------------------------------|
| FRIEDENSOHN, PETER&HOPKINS, P<br><br>2 BATTERY WHARF, UNIT 2042<br><br>BOSTON MA 02109 |  |  |             |                  |             |          | Description        | Code | Assessed  | Assessed  | 801<br><br>FY2025<br>BARNSTABLE, MA<br><br><b>VISION</b> |
|                                                                                        |  |  |             |                  |             |          | RESIDNTL           | 1010 | 1,005,300 | 1,005,300 |                                                          |
|                                                                                        |  |  |             |                  |             |          | RES LAND           | 1010 | 1,729,900 | 1,729,900 |                                                          |
| <b>SUPPLEMENTAL DATA</b>                                                               |  |  |             |                  |             |          |                    |      |           |           |                                                          |
|                                                                                        |  |  | Alt Prcl ID |                  | Plan Ref.   | 21/89    |                    |      |           |           |                                                          |
|                                                                                        |  |  | Split Zonin |                  | Land Ct#    | 15354-77 |                    |      |           |           |                                                          |
|                                                                                        |  |  | BID Parcel  |                  | #SR         |          |                    |      |           |           |                                                          |
|                                                                                        |  |  | ResExpt Q   |                  | Life Estate |          |                    |      |           |           |                                                          |
|                                                                                        |  |  | #DL 1       | LOTS 2 & 70      | PP STATU    |          |                    |      |           |           |                                                          |
|                                                                                        |  |  | #DL 2       |                  |             |          |                    |      |           |           |                                                          |
|                                                                                        |  |  | GIS ID      | F_951790_2687142 | Assoc Pid#  |          |                    |      |           |           |                                                          |
|                                                                                        |  |  |             |                  |             |          | Total              |      | 2,735,200 | 2,735,200 |                                                          |

| RECORD OF OWNERSHIP |  |  | BK-VOL/PAGE | SALE DATE | Q/U | V/I | SALE PRIC | VC | PREVIOUS ASSESSMENTS (HISTORY) |      |           |       |      |           |
|---------------------|--|--|-------------|-----------|-----|-----|-----------|----|--------------------------------|------|-----------|-------|------|-----------|
|                     |  |  |             |           |     |     |           |    | Year                           | Code | Assessed  | Year  | Code | Assessed  |
|                     |  |  |             |           |     |     |           |    | 2025                           | 1010 | 1,005,300 | 2024  | 1010 | 955,900   |
|                     |  |  |             |           |     |     |           |    |                                | 1010 | 1,729,900 |       | 1010 | 1,729,900 |
|                     |  |  |             |           |     |     |           |    | Total                          |      | 2,735,200 | Total |      | 2,685,800 |
|                     |  |  |             |           |     |     |           |    | Total                          |      |           | Total |      | 2,222,800 |

| EXEMPTIONS |      |             | OTHER ASSESSMENTS |      |             |        |        | APPRAISED VALUE SUMMARY |                                                                     |  |  |  |  |
|------------|------|-------------|-------------------|------|-------------|--------|--------|-------------------------|---------------------------------------------------------------------|--|--|--|--|
| Year       | Code | Description | Amount            | Code | Description | Number | Amount | Comm Int                | This signature acknowledges a visit by a Data Collector or Assessor |  |  |  |  |
|            |      |             |                   |      |             |        |        |                         | <b>APPRAISED VALUE SUMMARY</b>                                      |  |  |  |  |
|            |      |             |                   |      |             |        |        |                         | Appraised Bldg. Value (Card) 821,800                                |  |  |  |  |
|            |      |             |                   |      |             |        |        |                         | Appraised Xf (B) Value (Bldg) 64,800                                |  |  |  |  |
|            |      |             |                   |      |             |        |        |                         | Appraised Ob (B) Value (Bldg) 118,700                               |  |  |  |  |
|            |      |             |                   |      |             |        |        |                         | Appraised Land Value (Bldg) 1,729,900                               |  |  |  |  |
|            |      |             |                   |      |             |        |        |                         | Special Land Value 0                                                |  |  |  |  |
|            |      |             |                   |      |             |        |        |                         | Total Appraised Parcel Value 2,735,200                              |  |  |  |  |
|            |      |             |                   |      |             |        |        |                         | Valuation Method C                                                  |  |  |  |  |
|            |      |             |                   |      |             |        |        |                         | Total Appraised Parcel Value 2,735,200                              |  |  |  |  |

| BUILDING PERMIT RECORD |            |      |             |        |           |        |           | VISIT / CHANGE HISTORY |      |    |      |    |    |                |
|------------------------|------------|------|-------------|--------|-----------|--------|-----------|------------------------|------|----|------|----|----|----------------|
| Permit Id              | Issue Date | Type | Description | Amount | Insp Date | % Comp | Date Comp | Comments               | Date | Id | Type | Is | Cd | Purpost/Result |
|                        |            |      |             |        |           |        |           |                        |      |    |      |    |    |                |

| LAND LINE VALUATION SECTION |          |             |      |    |                        |            |          |         |            |                  |       |           |       |                    |            |            |
|-----------------------------|----------|-------------|------|----|------------------------|------------|----------|---------|------------|------------------|-------|-----------|-------|--------------------|------------|------------|
| B                           | Use Code | Description | Zone | LA | Land Units             | Unit Price | Size Adj | AC Disc | Site Index | Cond.            | Nbhd. | Nbhd. Adj | Notes | Location Adjustmen | Adj Unit P | Land Value |
|                             |          |             |      |    |                        |            |          |         |            |                  |       |           |       |                    |            |            |
| Total Card Land Units       |          |             |      |    | Parcel Total Land Area |            |          |         |            | Total Land Value |       |           |       |                    |            |            |

| CONSTRUCTION DETAIL                                                           |               |               |            |            |           | CONSTRUCTION DETAIL (CONTINUED) |      |             |            |             |     |
|-------------------------------------------------------------------------------|---------------|---------------|------------|------------|-----------|---------------------------------|------|-------------|------------|-------------|-----|
| Element                                                                       | Cd            | Description   |            |            |           | Element                         | Cd   | Description |            |             |     |
| Style                                                                         | 04            | Cape Cod      |            |            |           |                                 |      |             |            |             |     |
| Model                                                                         | 01            | Residential   |            |            |           |                                 |      |             |            |             |     |
| Grade:                                                                        | C+            | Average Plus  |            |            |           |                                 |      |             |            |             |     |
| Stories                                                                       | 1.75          | 1 3/4 Stories |            |            |           |                                 |      |             |            |             |     |
| Exterior Wall 1                                                               | 14            | Wood Shingle  |            |            |           | <b>CONDO DATA</b>               |      |             |            |             |     |
| Exterior Wall 2                                                               | 19            | Brick Veneer  |            |            |           | Parcel Id                       |      | C           |            | Owne        | 0.0 |
| Roof Structure                                                                | 03            | Gable/Hip     |            |            |           |                                 |      | B           |            | S           |     |
| Roof Cover                                                                    | 10            | Wood Shingle  |            |            |           | Adjust Type                     | Code | Description | Factor%    |             |     |
| Interior Wall 1                                                               | 05            | Drywall       |            |            |           | Condo Flr                       |      |             |            |             |     |
| Interior Wall 2                                                               |               |               |            |            |           | Condo Unit                      |      |             |            |             |     |
| Interior Floor 1                                                              | 12            | Hardwood      |            |            |           | <b>COST / MARKET VALUATION</b>  |      |             |            |             |     |
| Interior Floor 2                                                              | 14            | Carpet        |            |            |           | Building Value New              |      |             |            |             |     |
| Heat Fuel                                                                     | 02            | Oil           |            |            |           | Year Built                      |      |             |            |             |     |
| Heat Type                                                                     | 04            | Hot Air       |            |            |           | Effective Year Built            |      |             |            |             |     |
| AC Type                                                                       | 03            | Central       |            |            |           | Depreciation Code               |      |             |            |             |     |
| Bedrooms                                                                      | 05            | 5 Bedrooms    |            |            |           | Remodel Rating                  |      |             |            |             |     |
| Full Baths                                                                    | 4             |               |            |            |           | Year Remodeled                  |      |             |            |             |     |
| Half Baths                                                                    | 0             |               |            |            |           | Depreciation %                  |      |             |            |             |     |
| Extra Fixtures                                                                |               |               |            |            |           | Functional Obsol                |      |             |            |             |     |
| Total Rooms                                                                   | 9             | 9 Rooms       |            |            |           | External Obsol                  |      |             |            |             |     |
| Bath Style                                                                    |               |               |            |            |           | Trend Factor                    |      |             |            |             |     |
| Kitchen Style                                                                 |               |               |            |            |           | Condition                       |      |             |            |             |     |
| Occupancy                                                                     |               |               |            |            |           | Condition %                     |      |             |            |             |     |
| Sewer Occupan                                                                 |               |               |            |            |           | Percent Good                    |      |             |            |             |     |
| Accessory Apt                                                                 |               |               |            |            |           | RCNLD                           |      |             |            |             |     |
| Foundation Alt                                                                | 01            | Poured Conc.  |            |            |           | Dep % Ovr                       |      |             |            |             |     |
| Rms Prts                                                                      |               |               |            |            |           | Dep Ovr Comment                 |      |             |            |             |     |
| Bath Split                                                                    | 40            | 4 Full-0 Half |            |            |           | Misc Imp Ovr                    |      |             |            |             |     |
|                                                                               |               |               |            |            |           | Misc Imp Ovr Comment            |      |             |            |             |     |
|                                                                               |               |               |            |            |           | Cost to Cure Ovr                |      |             |            |             |     |
|                                                                               |               |               |            |            |           | Cost to Cure Ovr Comment        |      |             |            |             |     |
| <b>OB - OUTBUILDING &amp; YARD ITEMS(L) / XF - BUILDING EXTRA FEATURES(B)</b> |               |               |            |            |           |                                 |      |             |            |             |     |
| Code                                                                          | Description   | L/B           | Units      | Unit Price | Yr Blt    | Cond. Cd                        | % Gd | Grade       | Grade Adj. | Appr. Value |     |
| PRG1                                                                          | Pergola-Avg   | L             | 160        | 18.00      | 2011      |                                 | 74   | C           | 1.00       | 2,100       |     |
| SPDC                                                                          | POOL DECK     | L             | 520        | 5.61       | 2011      |                                 | 92   |             | 0.00       | 2,700       |     |
| FOPC                                                                          | Open Prch-roo | B             | 48         | 55.00      | 1988      |                                 | 74   |             | 0.00       | 2,100       |     |
| SOL2                                                                          | Solar PV Pane | B             | 48         | 725.00     | 1988      |                                 | 0    |             | 0.00       | 0           |     |
| <b>BUILDING SUB-AREA SUMMARY SECTION</b>                                      |               |               |            |            |           |                                 |      |             |            |             |     |
| Code                                                                          | Description   | Living Area   | Floor Area | Eff Area   | Unit Cost | Undeprec Value                  |      |             |            |             |     |
|                                                                               |               |               |            |            |           |                                 |      |             |            |             |     |
| Ttl Gross Liv / Lease Area                                                    |               |               |            |            |           |                                 |      |             |            |             |     |