

| CURRENT OWNER | | TOPO | UTILITIES | STRT / ROAD | LOCATION | CURRENT ASSESSMENT | | | | 801 FY2025 BARNSTABLE, MA VISION | |
|--|--|-------------|----------------|------------------|----------|-------------------------------------|----------------------|----------------------------------|----------------------------------|--|-----------|
| MAGALETTI, GERARD & PAULA 2890 HAMPTON CIRCLE EAST DELRAY BEACH FL 33445 | | 1 Level | 2 Public Water | 1 Paved | | Description RESIDNTL RES LAND | Code 1010 1010 | Assessed 1,182,300 300,000 | Assessed 1,182,300 300,000 | | |
| | | | 4 Gas | | | | | | | | |
| | | | 6 Septic | | 2 | | | | | | |
| SUPPLEMENTAL DATA | | | | | | Total | | | | 1,482,300 | 1,482,300 |
| Alt Prcl ID | | Split Zonin | | Plan Ref. 292/27 | | | | | | | |
| BID Parcel | | ResExpt Q | | Land Ct# | | | | | | | |
| #DL 1 LOT 80 | | #DL 2 | | Life Estate | | | | | | | |
| GIS ID F_951339_2693908 | | Assoc Pid# | | | | | | | | | |

| RECORD OF OWNERSHIP | | BK-VOL/PAGE | SALE DATE | Q/U | V/I | SALE PRIC | VC | PREVIOUS ASSESSMENTS (HISTORY) | | | | | | | | | |
|-----------------------------|-------|-------------|------------|-----|-----|-----------|----|--------------------------------|------|-----------|------|-----------|-----------|-------|------|-----------|--|
| MAGALETTI, GERARD & PAULA | 29888 | 0059 | 08-26-2016 | Q | I | 955,000 | 00 | Year | Code | Assessed | Year | Code | Assessed | Year | Code | Assessed | |
| CASO, DEAN C & JEANNE M | 20049 | 0194 | 07-15-2005 | U | I | 690,000 | 1A | 2025 | 1010 | 1,182,300 | 2024 | 1010 | 1,060,600 | 2023 | 1010 | 957,600 | |
| COUGHLIN, JOSEPH E TR | 10235 | 0342 | 06-15-1996 | U | I | 1 | A | | 1010 | 300,000 | | 1010 | 300,000 | | 1010 | 296,900 | |
| COUGHLIN, THOMAS F TR | 9108 | 0063 | 03-15-1994 | U | I | 1 | A | | | | | | | | | | |
| COUGHLIN, THOMAS F & MARY A | 6903 | 0180 | 10-15-1989 | Q | I | 350,000 | U | | | | | | | | | | |
| Total | | | | | | | | 1,482,300 | | Total | | 1,360,600 | | Total | | 1,254,500 | |

| EXEMPTIONS | | | OTHER ASSESSMENTS | | | | | This signature acknowledges a visit by a Data Collector or Assessor | | | | | | | | | | |
|------------|------|-------------|-------------------|------|-------------|--------|--------|---|--|--|--|--|--|--|--|--|--|--|
| Year | Code | Description | Amount | Code | Description | Number | Amount | Comm Int | | | | | | | | | | |
| Total | | | 0.00 | | | | | | | | | | | | | | | |

| ASSESSING NEIGHBORHOOD | | | | |
|------------------------|-----------|---|---------|-------|
| Nbhd | Nbhd Name | B | Tracing | Batch |
| 0108 | | | COTUIT | |

| NOTES | | | | | | | | | | | | | | |
|-------|--|--|--|--|--|--|--|--|--|--|--|--|--|--|
| | | | | | | | | | | | | | | |

| BUILDING PERMIT RECORD | | | | | | | | | | VISIT / CHANGE HISTORY | | | | | |
|------------------------|------------|------|---------------|--------|------------|--------|------------|---------------------|--|------------------------|----|------|----|----|-----------------------|
| Permit Id | Issue Date | Type | Description | Amount | Insp Date | % Comp | Date Comp | Comments | | Date | Id | Type | Is | Cd | Purpost/Result |
| 16-3584 | 12-09-2016 | 822 | Insulation | 2,800 | | 100 | | weatherization | | 10-25-2022 | BM | 22 | | 22 | Change of Address |
| 89757 | 01-18-2006 | RE | Remodel | 70,000 | 10-27-2006 | 100 | 06-30-2007 | PORCH, DRMRS, REMOD | | 06-08-2020 | WD | | | FR | Field Review |
| 87648 | 10-18-2005 | SP | Swimming Pool | 29,000 | 10-27-2006 | 100 | 06-30-2007 | | | 02-28-2018 | SR | 02 | | 03 | Cycl Insp Comp |
| 38317 | 05-10-1999 | RW | Repair Work | 4,200 | 01-01-2000 | 100 | 01-01-2000 | Replace deck | | 04-03-2015 | JR | 03 | | 03 | Cycl Insp Comp |
| B22894 | 03-01-1981 | DW | Dwelling | 0 | 01-15-1982 | 100 | 06-30-1982 | CO 2 STOR | | 08-24-2012 | RB | 03 | | 16 | In Office Review |
| | | | | | | | | | | 06-30-2008 | TP | 03 | | 16 | In Office Review |
| | | | | | | | | | | 06-05-2007 | JG | 03 | | 02 | Bldg Permit Completed |

| LAND LINE VALUATION SECTION | | | | | | | | | | | | | | | | | | | |
|-----------------------------|----------|----------------|------|----|------------|---------------|------------------------|---------|------------|-------|-------|-----------|------------------|--|--|--------------------|--|------------|------------|
| B | Use Code | Description | Zone | LA | Land Units | Unit Price | Size Adj | AC Disc | Site Index | Cond. | Nbhd. | Nbhd. Adj | Notes | | | Location Adjustmen | | Adj Unit P | Land Value |
| 1 | 1010 | Single Fam M-0 | RF | 2 | 1.000 | AC 176,344.00 | 1.00000 | 1.0000 | 5 | 1.00 | 0108 | 1.700 | | | | 1.0000 | | 299,784.8 | 299,800 |
| 1 | 1010 | Single Fam M-0 | RF | 2 | 0.010 | AC 14,250.00 | 1.00000 | 1.0000 | 0 | 1.00 | 0108 | 1.700 | | | | 1.0000 | | 24,225 | 200 |
| Total Card Land Units | | | | | 1.01 | AC | Parcel Total Land Area | | | | | 1.01 | Total Land Value | | | | | 300,000 | |

| CONSTRUCTION DETAIL | | | CONSTRUCTION DETAIL (CONTINUED) | | |
|--------------------------------|------|---------------|---------------------------------|-----|-------------|
| Element | Cd | Description | Element | Cd | Description |
| Style | 04 | Cape Cod | | | |
| Model | 01 | Residential | | | |
| Grade: | B | Custom | | | |
| Stories | 2 | 2 Stories | | | |
| Exterior Wall 1 | 14 | Wood Shingle | | | |
| Exterior Wall 2 | | | | | |
| Roof Structure | 07 | Gambrel | | | |
| Roof Cover | 10 | Wood Shingle | | | |
| Interior Wall 1 | 03 | Plastered | | | |
| Interior Wall 2 | | | | | |
| Interior Floor 1 | 12 | Hardwood | | | |
| Interior Floor 2 | 14 | Carpet | | | |
| Heat Fuel | 03 | Gas | | | |
| Heat Type | 04 | Hot Air | | | |
| AC Type | 03 | Central | | | |
| Bedrooms | 05 | 5 Bedrooms | | | |
| Full Baths | 3 | | | | |
| Half Baths | 0 | | | | |
| Extra Fixtures | | | | | |
| Total Rooms | 9 | | | | |
| Bath Style | | | | | |
| Kitchen Style | | | | | |
| Occupancy | | | | | |
| Sewer Occupan | | | | | |
| Accessory Apt | | | | | |
| Foundation Alt | 01 | Poured Conc. | | | |
| Rms Prts | | | | | |
| Bath Split | 30 | 3 Full-0 Half | | | |
| CONDO DATA | | | | | |
| Parcel Id | | C | Owne | 0.0 | |
| Adjust Type | Code | Description | Factor% | | |
| Condo Flr | | | | | |
| Condo Unit | | | | | |
| COST / MARKET VALUATION | | | | | |
| Building Value New | | | 1,203,323 | | |
| Year Built | | | 1981 | | |
| Effective Year Built | | | 2005 | | |
| Depreciation Code | | | G | | |
| Remodel Rating | | | | | |
| Year Remodeled | | | | | |
| Depreciation % | | | 15 | | |
| Functional Obsol | | | 0 | | |
| External Obsol | | | 0 | | |
| Trend Factor | | | 1 | | |
| Condition | | | | | |
| Condition % | | | | | |
| Percent Good | | | 85 | | |
| RCNLD | | | 1,022,800 | | |
| Dep % Ovr | | | | | |
| Dep Ovr Comment | | | | | |
| Misc Imp Ovr | | | | | |
| Misc Imp Ovr Comment | | | | | |
| Cost to Cure Ovr | | | | | |
| Cost to Cure Ovr Comment | | | | | |

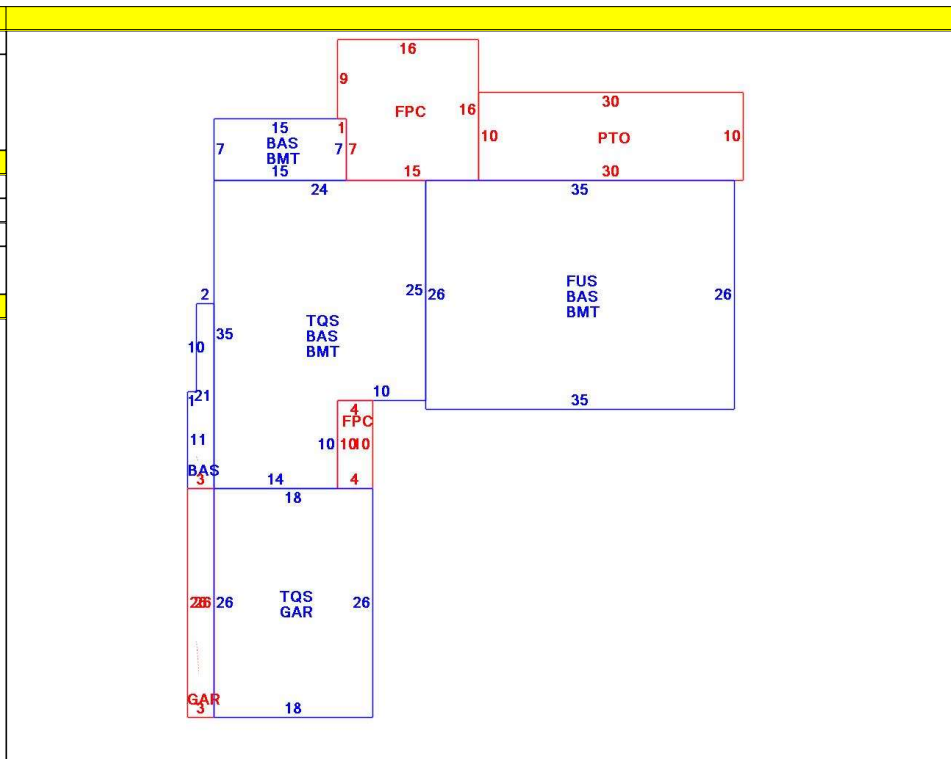

| OB - OUTBUILDING & YARD ITEMS(L) / XF - BUILDING EXTRA FEATURES(B) | | | | | | | | | | |
|--|-----------------|-----|-------|------------|--------|----------|------|-------|------------|-------------|
| Code | Description | L/B | Units | Unit Price | Yr Blt | Cond. Cd | % Gd | Grade | Grade Adj. | Appr. Value |
| FPL3 | Fireplace 2 sto | B | 2 | 7000.00 | 2003 | | 85 | | 0.00 | 11,900 |
| SPL3 | Pool Gunite | L | 864 | 75.00 | 2006 | | 64 | 00 | 1.00 | 40,900 |
| PAT2 | Patio-Good | L | 300 | 9.94 | 2006 | | 87 | | 0.00 | 2,600 |
| FOP | Open Porch-ro | B | 289 | 55.00 | 2003 | | 85 | | 0.00 | 9,800 |
| GAR | Attached Gara | B | 546 | 40.00 | 2003 | | 85 | | 0.00 | 16,700 |
| BMT | Basement-Unfi | B | 1,755 | 26.01 | 2003 | | 85 | | 0.00 | 34,100 |
| PAT2 | Patio-Good | L | 2,196 | 9.94 | 2017 | | 98 | | 0.00 | 17,400 |
| PHS2 | Pool Hs/Avg.pl | L | 198 | 120.00 | 2017 | | 93 | C | 1.00 | 22,100 |
| SPH3 | Pool Heater 80 | L | 1 | 4116.00 | 2017 | | 96 | | 0.00 | 4,000 |

| BUILDING SUB-AREA SUMMARY SECTION | | | | | | |
|-----------------------------------|------------------------|-------------|------------|----------|-----------|----------------|
| Code | Description | Living Area | Floor Area | Eff Area | Unit Cost | Undeprec Value |
| BAS | First Floor | 1,808 | 1,808 | 1,808 | 343.51 | 621,070 |
| BMT | Basement Area | 0 | 1,755 | 0 | 0.00 | 0 |
| FPC | Open Porch Conc. Floor | 0 | 289 | 0 | 0.00 | 0 |
| FUS | Upper Story | 910 | 910 | 910 | 343.51 | 312,596 |
| GAR | Attached Garage | 0 | 546 | 0 | 0.00 | 0 |
| PTO | Patio | 0 | 300 | 0 | 0.00 | 0 |
| TQS | Three Quarter Story | 785 | 1,208 | 785 | 223.23 | 269,657 |
| Ttl Gross Liv / Lease Area | | 3,503 | 6,816 | 3,503 | | 1,203,323 |

