

| CURRENT OWNER | | TOPO | UTILITIES | STRT / ROAD | LOCATION | CURRENT ASSESSMENT | | | |
|--|--|---------|----------------|-------------|--|--------------------|-------|----------|----------|
| SWAIN, NASON H PO BOX 2389 TEATICKET MA 02536 | | 1 Level | 2 Public Water | | 9 Rear Location | Description | Code | Assessed | Assessed |
| | | | 4 Gas | | | RESIDNTL | 1090 | 221,000 | 221,000 |
| | | | 6 Septic | 1 Paved | 6 | RES LAND | 1090 | 185,100 | 185,100 |
| SUPPLEMENTAL DATA | | | | | | | | | |
| Alt Prcl ID Split Zonin BID Parcel ResExpt Q #DL 1 LOT B #DL 2 GIS ID F_954243_2700553 | | | | | Plan Ref. 307/52 Land Ct# #SR Life Estate PP STATU Assoc Pid# | | Total | | 406,100 |

801
 FY2025
 BARNSTABLE, MA

VISION

| RECORD OF OWNERSHIP | | BK-VOL/PAGE | SALE DATE | Q/U | V/I | SALE PRIC | VC | PREVIOUS ASSESSMENTS (HISTORY) | | | | | |
|---------------------|--|-------------|------------|-----|-----|-----------|----|--------------------------------|------|----------|-------|------|----------|
| SWAIN, NASON H | | 27480 0253 | 06-21-2013 | U | I | 1 | 1F | Year | Code | Assessed | Year | Code | Assessed |
| SWAIN, NASON H TR | | 25749 0172 | 10-13-2011 | U | I | 1 | 1F | 2025 | 1090 | 221,000 | 2024 | 1090 | 225,300 |
| SWAIN, NASON H | | 13595 0060 | 02-27-2001 | Q | I | 170,000 | 00 | | 1090 | 185,100 | 2023 | 1090 | 223,900 |
| BARRY, JAMES J | | 3686 0102 | 03-15-1983 | Q | I | 41,500 | U | Total | | 406,100 | Total | | 410,400 |
| | | | | | | | | Total | | 393,000 | Total | | 393,000 |

| EXEMPTIONS | | | OTHER ASSESSMENTS | | | | | |
|------------|------|-------------|-------------------|------|-------------|--------|--------|----------|
| Year | Code | Description | Amount | Code | Description | Number | Amount | Comm Int |
| | | Total | 0.00 | | | | | |

This signature acknowledges a visit by a Data Collector or Assessor

| ASSESSING NEIGHBORHOOD | | | |
|------------------------|-----------|---|---------|
| Nbhd | Nbhd Name | B | Tracing |
| 0105 | | | MARSTM |

| NOTES | | | |
|-------|--|--|--|
| | | | |

| APPRAISED VALUE SUMMARY | |
|-------------------------------|---------|
| Appraised Bldg. Value (Card) | 173,600 |
| Appraised Xf (B) Value (Bldg) | 35,900 |
| Appraised Ob (B) Value (Bldg) | 11,500 |
| Appraised Land Value (Bldg) | 185,100 |
| Special Land Value | 0 |
| Total Appraised Parcel Value | 406,100 |
| Valuation Method | C |
| Total Appraised Parcel Value | 406,100 |

| BUILDING PERMIT RECORD | | | | | | | | VISIT / CHANGE HISTORY | | | | | | |
|------------------------|------------|------|-------------|--------|-----------|--------|-----------|---------------------------|------------|----|------|----|----|----------------------------|
| Permit Id | Issue Date | Type | Description | Amount | Insp Date | % Comp | Date Comp | Comments | Date | Id | Type | Is | Cd | Purpost/Result |
| 19-2828 | 03-23-2020 | 822 | Insulation | 4,800 | | 100 | | Insulation/Weatherization | 11-02-2020 | SR | 02 | | 03 | Cycl Insp Comp |
| 19-2825 | 08-30-2019 | 822 | Insulation | 2,900 | | 100 | | Insulation/Weatherization | 06-02-2020 | DM | | | FR | Field Review |
| | | | | | | | | | 04-05-2016 | AL | 22 | | 22 | Change of Address |
| | | | | | | | | | 11-28-2005 | PT | 02 | | 01 | Meas/Est |
| | | | | | | | | | 01-15-1999 | FS | 01 | | 00 | Meas/Listed-Interior Acces |

| LAND LINE VALUATION SECTION | | | | | | | | | | | | | | | | |
|-----------------------------|----------|-----------------|------|----|------------|------------|------------------------|---------|------------|-------|-------|-----------|------------------|--------------------|------------|------------|
| B | Use Code | Description | Zone | LA | Land Units | Unit Price | Size Adj | AC Disc | Site Index | Cond. | Nbhd. | Nbhd. Adj | Notes | Location Adjustmen | Adj Unit P | Land Value |
| 1 | 1090 | Multi Hses M-01 | RF | 3 | 1.000 AC | 176,344.00 | 1.00000 | 1.0000 | 5 | 1.00 | 0105 | 1.000 | | 1.0000 | 176,344 | 176,300 |
| Total Card Land Units | | | | | 1.00 | AC | Parcel Total Land Area | | | | | 1.62 | Total Land Value | | | 176,300 |

| CONSTRUCTION DETAIL | | | CONSTRUCTION DETAIL (CONTINUED) | | |
|---------------------|----|----------------|--------------------------------------|----|-------------|
| Element | Cd | Description | Element | Cd | Description |
| Style | 36 | Cottage | | | |
| Model | 01 | Residential | | | |
| Grade: | C | Average | | | |
| Stories | 1 | 1 Story | | | |
| Exterior Wall 1 | 25 | Vinyl Siding | | | |
| Exterior Wall 2 | 14 | Wood Shingle | | | |
| Roof Structure | 03 | Gable/Hip | | | |
| Roof Cover | 03 | Asph/F Gls/Cmp | | | |
| Interior Wall 1 | 05 | Drywall | | | |
| Interior Wall 2 | | | | | |
| Interior Floor 1 | 14 | Carpet | | | |
| Interior Floor 2 | | | | | |
| Heat Fuel | 03 | Gas | | | |
| Heat Type | 05 | Hot Water | | | |
| AC Type | 01 | None | | | |
| Bedrooms | 01 | 1 Bedroom | | | |
| Full Baths | 1 | | | | |
| Half Baths | 0 | | | | |
| Extra Fixtures | | | | | |
| Total Rooms | 3 | 3 Rooms | | | |
| Bath Style | | | | | |
| Kitchen Style | | | | | |
| Occupancy | | | | | |
| Sewer Occupan | 2 | | | | |
| Accessory Apt | | | | | |
| Foundation Alt | 02 | Conc. Block | | | |
| Rms Prts | | | | | |
| Bath Split | 10 | 1 Full-0 Half | | | |
| | | | CONDO DATA | | |
| | | | Parcel Id | C | Owne 0.0 |
| | | | Adjust Type Code Description Factor% | | |
| | | | Condo Flr | | |
| | | | Condo Unit | | |
| | | | COST / MARKET VALUATION | | |
| | | | Building Value New | | 136,935 |
| | | | Year Built | | 1957 |
| | | | Effective Year Built | | 1988 |
| | | | Depreciation Code | | A |
| | | | Remodel Rating | | |
| | | | Year Remodeled | | |
| | | | Depreciation % | | 28 |
| | | | Functional Obsol | | 0 |
| | | | External Obsol | | 0 |
| | | | Trend Factor | | 1 |
| | | | Condition | | |
| | | | Condition % | | |
| | | | Percent Good | | 72 |
| | | | RCNLD | | 98,600 |
| | | | Dep % Ovr | | |
| | | | Dep Ovr Comment | | |
| | | | Misc Imp Ovr | | |
| | | | Misc Imp Ovr Comment | | |
| | | | Cost to Cure Ovr | | |
| | | | Cost to Cure Ovr Comment | | |

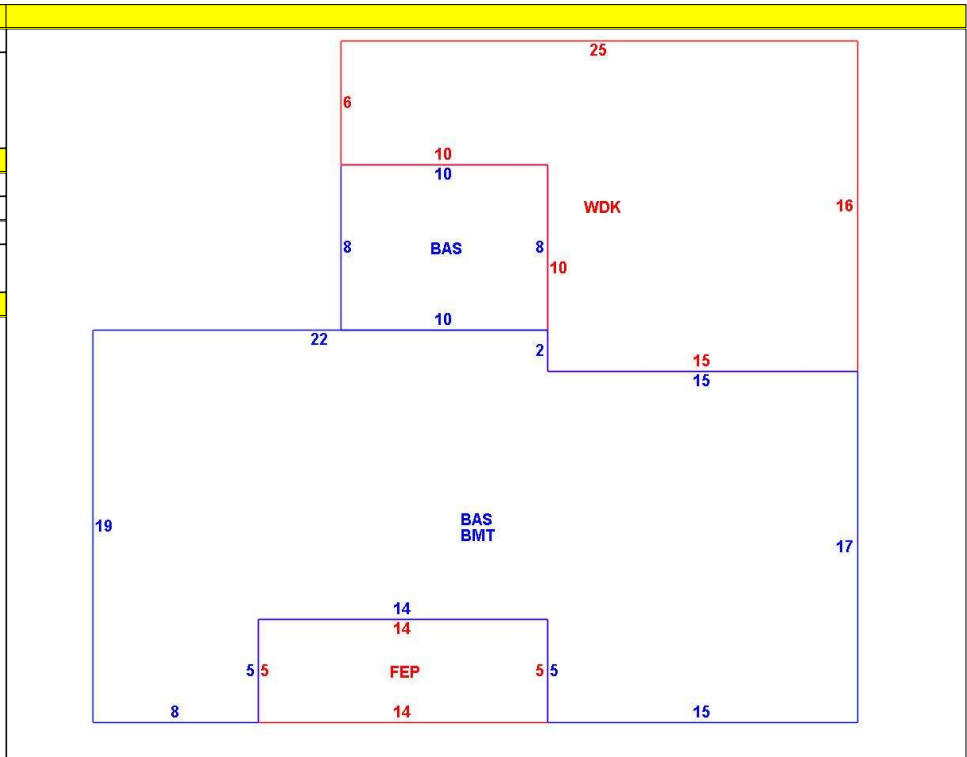

| OB - OUTBUILDING & YARD ITEMS(L) / XF - BUILDING EXTRA FEATURES(B) | | | | | | | | | | |
|--|---------------|-----|-------|------------|--------|----------|------|-------|------------|-------------|
| Code | Description | L/B | Units | Unit Price | Yr Blt | Cond. Cd | % Gd | Grade | Grade Adj. | Appr. Value |
| FGR2 | Garage- Avg- | L | 528 | 50.00 | 1957 | | 33 | 00 | 1.00 | 8,700 |
| WDC | Wood Decking | L | 300 | 20.00 | 1992 | | 46 | | 0.00 | 2,800 |
| FEP | Enclosed porc | B | 70 | 70.00 | 1986 | | 72 | | 0.00 | 4,800 |
| BMT | Basement-Unfi | B | 603 | 26.01 | 1986 | | 72 | | 0.00 | 13,800 |

| BUILDING SUB-AREA SUMMARY SECTION | | | | | | |
|-----------------------------------|----------------|-------------|------------|----------|-----------|----------------|
| Code | Description | Living Area | Floor Area | Eff Area | Unit Cost | Undeprec Value |
| BAS | First Floor | 683 | 683 | 683 | 200.49 | 136,935 |
| BMT | Basement Area | 0 | 603 | 0 | 0.00 | 0 |
| FEP | Enclosed Porch | 0 | 70 | 0 | 0.00 | 0 |
| WDK | Wood Deck | 0 | 300 | 0 | 0.00 | 0 |
| Ttl Gross Liv / Lease Area | | 683 | 1,656 | 683 | | 136,935 |



| CURRENT OWNER | | TOPO | UTILITIES | STRT / ROAD | LOCATION | CURRENT ASSESSMENT | | | | 801 FY2025 BARNSTABLE, MA VISION |
|---|--|-------------|----------------|------------------|-----------------|--------------------|------|----------|----------|--|
| SWAIN, NASON H PO BOX 2389 TEATICKET MA 02536 | | 1 Level | 2 Public Water | | 9 Rear Location | Description | Code | Assessed | Assessed | |
| | | | 4 Gas | | | RESIDNTL | 1090 | 221,000 | 221,000 | |
| | | | 6 Septic | 1 Paved | 6 | RES LAND | 1090 | 185,100 | 185,100 | |
| SUPPLEMENTAL DATA | | | | | | Total | | | | 406,100 |
| Alt Prcl ID | | Split Zonin | | Plan Ref. 307/52 | | | | | | |
| BID Parcel | | | | Land Ct# | | | | | | |
| ResExpt Q | | | | #SR | | | | | | |
| #DL 1 LOT B | | | | Life Estate | | | | | | |
| #DL 2 | | | | PP STATU | | | | | | |
| GIS ID F_954243_2700553 | | | | Assoc Pid# | | | | | | |

| RECORD OF OWNERSHIP | | BK-VOL/PAGE | SALE DATE | Q/U | V/I | SALE PRIC | VC | PREVIOUS ASSESSMENTS (HISTORY) | | | | | |
|---------------------|-------|-------------|------------|-----|-----|-----------|----|--------------------------------|------|----------|-------|------|----------|
| SWAIN, NASON H | 27480 | 0253 | 06-21-2013 | U | I | 1 | 1F | Year | Code | Assessed | Year | Code | Assessed |
| SWAIN, NASON H TR | 25749 | 0172 | 10-13-2011 | U | I | 1 | 1F | 2025 | 1090 | 221,000 | 2024 | 1090 | 225,300 |
| SWAIN, NASON H | 13595 | 0060 | 02-27-2001 | Q | I | 170,000 | 00 | | 1090 | 185,100 | | 1090 | 185,100 |
| BARRY, JAMES J | 3686 | 0102 | 03-15-1983 | Q | I | 41,500 | U | Total | | 406,100 | Total | | 410,400 |
| | | | | | | | | Total | | 393,000 | Total | | 393,000 |

| EXEMPTIONS | | | OTHER ASSESSMENTS | | | | This signature acknowledges a visit by a Data Collector or Assessor | | | | | |
|------------|------|-------------|-------------------|------|-------------|--------|---|----------|--|--|--|--|
| Year | Code | Description | Amount | Code | Description | Number | Amount | Comm Int | | | | |
| | | | | | | | | | | | | |
| Total | | | 0.00 | | | | | | | | | |

| ASSESSING NEIGHBORHOOD | | | | APPRAISED VALUE SUMMARY | | | | |
|------------------------|-----------|---|---------|-------------------------|-------------------------------|---------|--|--|
| Nbhd | Nbhd Name | B | Tracing | Batch | | | | |
| 0105 | | | MARSTM | | Appraised Bldg. Value (Card) | 173,600 | | |
| | | | | | Appraised Xf (B) Value (Bldg) | 35,900 | | |
| | | | | | Appraised Ob (B) Value (Bldg) | 11,500 | | |
| | | | | | Appraised Land Value (Bldg) | 185,100 | | |
| | | | | | Special Land Value | 0 | | |
| | | | | | Total Appraised Parcel Value | 406,100 | | |
| | | | | | Valuation Method | C | | |
| | | | | | Total Appraised Parcel Value | 406,100 | | |

| BUILDING PERMIT RECORD | | | | | | | VISIT / CHANGE HISTORY | | | | | | | |
|------------------------|------------|------|-------------|--------|-----------|--------|------------------------|----------|------|----|------|----|----|----------------|
| Permit Id | Issue Date | Type | Description | Amount | Insp Date | % Comp | Date Comp | Comments | Date | Id | Type | Is | Cd | Purpost/Result |
| | | | | | | | | | | | | | | |

| LAND LINE VALUATION SECTION | | | | | | | | | | | | | | | | | |
|-----------------------------|----------|-----------------|------|----|------------|------------|------------------------|---------|------------|-------|-------|-----------|------------------|--------------------|------------|------------|-------|
| B | Use Code | Description | Zone | LA | Land Units | Unit Price | Size Adj | AC Disc | Site Index | Cond. | Nbhd. | Nbhd. Adj | Notes | Location Adjustmen | Adj Unit P | Land Value | |
| 2 | 1090 | Multi Hses M-01 | RF | 3 | 0.620 | AC | 14,250.00 | 1.00000 | 1.0000 | 0 | 1.00 | 0105 | 1.000 | | 1.0000 | 14,250 | 8,800 |
| Total Card Land Units | | | | | 0.62 | AC | Parcel Total Land Area | | | | | 1.62 | Total Land Value | | | 8,800 | |

| CONSTRUCTION DETAIL | | | CONSTRUCTION DETAIL (CONTINUED) | | |
|---------------------|----|----------------|---------------------------------|----|-------------|
| Element | Cd | Description | Element | Cd | Description |
| Style | 36 | Cottage | | | |
| Model | 01 | Residential | | | |
| Grade: | D+ | Below Average | | | |
| Stories | 1 | 1 Story | | | |
| Exterior Wall 1 | 25 | Vinyl Siding | | | |
| Exterior Wall 2 | | | | | |
| Roof Structure | 03 | Gable/Hip | | | |
| Roof Cover | 03 | Asph/F Gls/Cmp | | | |
| Interior Wall 1 | 05 | Drywall | | | |
| Interior Wall 2 | | | | | |
| Interior Floor 1 | 14 | Carpet | | | |
| Interior Floor 2 | | | | | |
| Heat Fuel | 03 | Gas | | | |
| Heat Type | 04 | Hot Air | | | |
| AC Type | 01 | None | | | |
| Bedrooms | 01 | 1 Bedroom | | | |
| Full Baths | 1 | | | | |
| Half Baths | 0 | | | | |
| Extra Fixtures | | | | | |
| Total Rooms | 3 | 3 Rooms | | | |
| Bath Style | | | | | |
| Kitchen Style | | | | | |
| Occupancy | | | | | |
| Sewer Occupan | | | | | |
| Accessory Apt | | | | | |
| Foundation Alt | 02 | Conc. Block | | | |
| Rms Prts | | | | | |
| Bath Split | 10 | 1 Full-0 Half | | | |

| CONDO DATA | | | | |
|-------------|------|-------------|---------|----------|
| Parcel Id | | C | | Ownr 0.0 |
| | | | B | S |
| Adjust Type | Code | Description | Factor% | |
| Condo Flr | | | | |
| Condo Unit | | | | |

| COST / MARKET VALUATION | |
|--------------------------|---------|
| Building Value New | 104,164 |
| Year Built | 1957 |
| Effective Year Built | 1988 |
| Depreciation Code | A |
| Remodel Rating | |
| Year Remodeled | |
| Depreciation % | 28 |
| Functional Obsol | 0 |
| External Obsol | 0 |
| Trend Factor | 1 |
| Condition | |
| Condition % | |
| Percent Good | 72 |
| RCNLD | 75,000 |
| Dep % Ovr | |
| Dep Ovr Comment | |
| Misc Imp Ovr | |
| Misc Imp Ovr Comment | |
| Cost to Cure Ovr | |
| Cost to Cure Ovr Comment | |

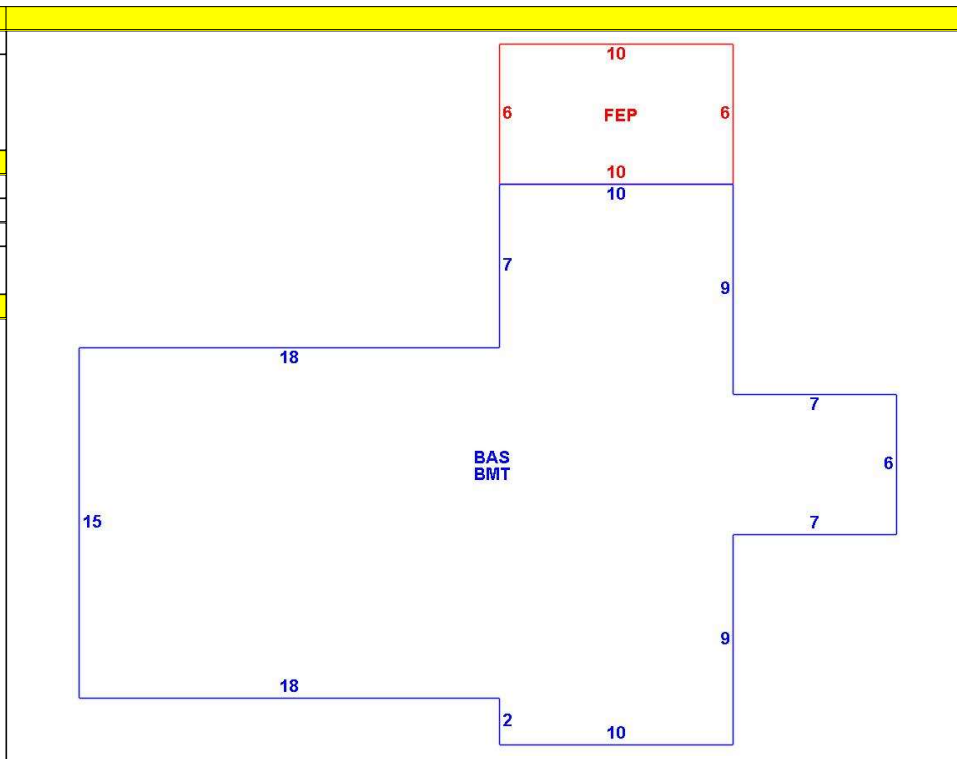

| OB - OUTBUILDING & YARD ITEMS(L) / XF - BUILDING EXTRA FEATURES(B) | | | | | | | | | | |
|--|---------------|-----|-------|------------|--------|----------|------|-------|------------|-------------|
| Code | Description | L/B | Units | Unit Price | Yr Blt | Cond. Cd | % Gd | Grade | Grade Adj. | Appr. Value |
| FEP | Enclosed porc | B | 60 | 70.00 | 1986 | | 72 | | 0.00 | 4,300 |
| BMT | Basement-Unfi | B | 552 | 26.01 | 1986 | | 72 | | 0.00 | 13,000 |

| BUILDING SUB-AREA SUMMARY SECTION | | | | | | |
|-----------------------------------|----------------|-------------|------------|----------|-----------|----------------|
| Code | Description | Living Area | Floor Area | Eff Area | Unit Cost | Undeprec Value |
| BAS | First Floor | 552 | 552 | 552 | 188.70 | 104,164 |
| BMT | Basement Area | 0 | 552 | 0 | 0.00 | 0 |
| FEP | Enclosed Porch | 0 | 60 | 0 | 0.00 | 0 |
| Ttl Gross Liv / Lease Area | | 552 | 1,164 | 552 | | 104,164 |

