

| CURRENT OWNER  |  | TOPO  | UTILITIES  | STRT / ROAD | LOCATION | CURRENT ASSESSMENT                   |                      |                                |                                 |
|--|--|---|--|-------------|----------|--------------------------------------|----------------------|--------------------------------|---------------------------------|
| ST MARY, CHRISTOPHER & JASON T<br>MICHAEL & KATHERINE ST MARY IR<br>113 MISTIC DRIVE |  | 1 Level   | 6 Septic   | 1 Paved     |          | Description<br>RESIDENTL<br>RES LAND | Code<br>1010<br>1010 | Assessed<br>849,400<br>247,500 | Assessed<br>849,400<br>247,500  |
|  |  |   | 4 Gas  |             |          |                                      |                      |                                |                                 |
| MARSTONS MIL MA 02648  |  | SUPPLEMENTAL DATA   |  |             |          | Total                                | 1,096,900            | 1,096,900                      | 801<br>FY2025<br>BARNSTABLE, MA |
|  |  | Alt Prcl ID<br>Split Zonin<br>BID Parcel<br>ResExpt Q<br>#DL 1 LOT 52<br>#DL 2<br>GIS ID F_953429_2703689 | Plan Ref. 203/53<br>Land Ct#<br>#SR<br>Life Estate<br>PP STATU<br>Assoc Pid# |             |          |                                      |                      |                                |                                 |

**VISION**

| RECORD OF OWNERSHIP  |  | BK-VOL/PAGE | SALE DATE  | Q/U | V/I | SALE PRIC | VC | PREVIOUS ASSESSMENTS (HISTORY) |      |           |       |      |           |
|--|--|-------------|------------|-----|-----|-----------|----|--------------------------------|------|-----------|-------|------|-----------|
| ST MARY, CHRISTOPHER & JASON TRS                           |  | 32268 0242  | 09-04-2019 | U   | I   | 100       | 1F | Year                           | Code | Assessed  | Year  | Code | Assessed  |
| ST MARY, MICHAEL & KATHERINE<br>FATER, MARC C & C PATRICIA |  | 31136 0320  | 03-15-2018 | Q   | I   | 623,000   | 00 | 2025                           | 1010 | 849,400   | 2024  | 1010 | 795,000   |
| SINSIMER, LAWRENCE M & AMY<br>NEW HARBOR BUILDING CORP     |  | 9979 0230   | 12-15-1995 | Q   | I   | 385,000   | U  |                                | 1010 | 247,500   | 2023  | 1010 | 697,700   |
|  |  | 6511 0326   | 11-15-1988 | Q   | I   | 360,000   | U  |                                |      |           |       |      | 225,000   |
|  |  | 5222 0102   | 07-15-1986 | U   | V   | 1         | B  |                                |      |           |       |      |           |
|  |  |             |            |     |     |           |    | Total                          |      | 1,096,900 | Total |      | 1,042,500 |
|  |  |             |            |     |     |           |    |                                |      |           | Total |      | 922,700   |

| EXEMPTIONS |      |             | OTHER ASSESSMENTS |      |             |        |        |          |
|------------|------|-------------|-------------------|------|-------------|--------|--------|----------|
| Year       | Code | Description | Amount            | Code | Description | Number | Amount | Comm Int |
|            |      |             |                   |      |             |        |        |          |
| Total      |      |             | 0.00              |      |             |        |        |          |

This signature acknowledges a visit by a Data Collector or Assessor

| ASSESSING NEIGHBORHOOD |           |   |         |
|------------------------|-----------|---|---------|
| Nbhd                   | Nbhd Name | B | Tracing |
| 0108                   |           |   | MARSTM  |

| APPRAISED VALUE SUMMARY       |           |
|-------------------------------|-----------|
| Appraised Bldg. Value (Card)  | 755,800   |
| Appraised Xf (B) Value (Bldg) | 87,300    |
| Appraised Ob (B) Value (Bldg) | 6,300     |
| Appraised Land Value (Bldg)   | 247,500   |
| Special Land Value            | 0         |
| Total Appraised Parcel Value  | 1,096,900 |
| Valuation Method              | C         |
| Total Appraised Parcel Value  | 1,096,900 |

| BUILDING PERMIT RECORD |            |      |                |        |            |        |            |                                  | VISIT / CHANGE HISTORY |    |      |    |    |                       |
|------------------------|------------|------|----------------|--------|------------|--------|------------|----------------------------------|------------------------|----|------|----|----|-----------------------|
| Permit Id              | Issue Date | Type | Description    | Amount | Insp Date  | % Comp | Date Comp  | Comments                         | Date                   | Id | Type | Is | Cd | Purpost/Result        |
| BLDR-23-23             | 02-24-2023 | 804  | Addn Alt-Res   | 6,000  | 06-30-2023 | 100    | 06-30-2023 | Build a 8x30 porch to front of h | 08-03-2023             | SR | 01   |    | 02 | Bldg Permit Completed |
| 20-576                 | 03-23-2020 | 835  | Sid/Wind/Roof/ | 18,010 | 06-30-2020 | 100    | 06-30-2020 | Removing siding on front wind    | 05-12-2020             | LS |      |    | FR | Field Review          |
| 19-826                 | 03-19-2019 | 804  | Addn Alt-Res   | 4,500  | 06-30-2019 | 100    | 06-30-2019 | Adda 15x20 Pavilion attached     | 02-24-2020             | CK | 22   |    | 22 | Change of Address     |
| 20064619               | 11-15-2006 | PV   | Solar PV Syste | 20,000 | 08-16-2016 | 100    | 06-30-2017 | 32 PANELS EVERGREEN EC           | 09-04-2019             | SR | 02   |    | 02 | Bldg Permit Completed |
| 76645                  | 05-11-2004 | NS   | New Siding     | 5,000  | 10-26-2004 | 100    | 01-01-2005 |                                  | 08-18-2016             | KM | 02   |    | 03 | Cycl Insp Comp        |
| B32669                 | 03-01-1989 | AD   | Addition       | 19,000 | 01-15-1990 | 100    | 12-31-1990 | MM REMOD'                        |                        |    |      |    |    |                       |
| B29383                 | 05-01-1986 | DW   | Dwelling       | 0      | 01-15-1988 | 100    | 12-31-1988 | MM 11/2 S                        |                        |    |      |    |    |                       |

| LAND LINE VALUATION SECTION |          |                |      |    |            |               |                        |         |            |       |       |           |                  |                    |            |            |
|-----------------------------|----------|----------------|------|----|------------|---------------|------------------------|---------|------------|-------|-------|-----------|------------------|--------------------|------------|------------|
| B                           | Use Code | Description    | Zone | LA | Land Units | Unit Price    | Size Adj               | AC Disc | Site Index | Cond. | Nbhd. | Nbhd. Adj | Notes            | Location Adjustmen | Adj Unit P | Land Value |
| 1                           | 1010     | Single Fam M-0 | RF   | 3  | 1.000      | AC 176,344.00 | 1.00000                | 1.0000  | 5          | 1.00  | 0107  | 1.400     |                  | 1.0000             | 246,881.6  | 246,900    |
| 1                           | 1010     | Single Fam M-0 | RF   | 3  | 0.030      | AC 14,250.00  | 1.00000                | 1.0000  | 0          | 1.00  | 0107  | 1.400     |                  | 1.0000             | 19,950     | 600        |
| Total Card Land Units       |          |                |      |    | 1.03       | AC            | Parcel Total Land Area |         |            |       |       | 1.03      | Total Land Value |                    |            | 247,500    |

| CONSTRUCTION DETAIL |      |                | CONSTRUCTION DETAIL (CONTINUED) |    |             |
|---------------------|------|----------------|---------------------------------|----|-------------|
| Element             | Cd   | Description    | Element                         | Cd | Description |
| Style               | 04   | Cape Cod       |                                 |    |             |
| Model               | 01   | Residential    |                                 |    |             |
| Grade:              | C+   | Average Plus   |                                 |    |             |
| Stories             | 1.75 | 1 3/4 Stories  |                                 |    |             |
| Exterior Wall 1     | 14   | Wood Shingle   |                                 |    |             |
| Exterior Wall 2     | 11   | Clapboard      |                                 |    |             |
| Roof Structure      | 03   | Gable/Hip      |                                 |    |             |
| Roof Cover          | 03   | Asph/F Gls/Cmp |                                 |    |             |
| Interior Wall 1     | 03   | Plastered      |                                 |    |             |
| Interior Wall 2     |      |                |                                 |    |             |
| Interior Floor 1    | 14   | Carpet         |                                 |    |             |
| Interior Floor 2    | 12   | Hardwood       |                                 |    |             |
| Heat Fuel           | 03   | Gas            |                                 |    |             |
| Heat Type           | 05   | Hot Water      |                                 |    |             |
| AC Type             | 03   | Central        |                                 |    |             |
| Bedrooms            | 05   | 5 Bedrooms     |                                 |    |             |
| Full Baths          | 3    |                |                                 |    |             |
| Half Baths          | 1    |                |                                 |    |             |
| Extra Fixtures      |      |                |                                 |    |             |
| Total Rooms         | 8    |                |                                 |    |             |
| Bath Style          |      |                |                                 |    |             |
| Kitchen Style       |      |                |                                 |    |             |
| Occupancy           |      |                |                                 |    |             |
| Sewer Occupan       |      |                |                                 |    |             |
| Accessory Apt       |      |                |                                 |    |             |
| Foundation Alt      | 01   | Poured Conc.   |                                 |    |             |
| Rms Prts            |      |                |                                 |    |             |
| Bath Split          | 31   | 3 Full-1 Half  |                                 |    |             |

| CONDO DATA  |      |             |         |     |
|-------------|------|-------------|---------|-----|
| Parcel Id   |      | C           | Owne    | 0.0 |
| Adjust Type | Code | Description | Factor% |     |
| Condo Flr   |      |             |         |     |
| Condo Unit  |      |             |         |     |

| COST / MARKET VALUATION  |  |         |
|--------------------------|--|---------|
| Building Value New       |  | 899,714 |
| Year Built               |  | 1986    |
| Effective Year Built     |  | 2003    |
| Depreciation Code        |  | A       |
| Remodel Rating           |  |         |
| Year Remodeled           |  |         |
| Depreciation %           |  | 16      |
| Functional Obsol         |  | 0       |
| External Obsol           |  | 0       |
| Trend Factor             |  | 1       |
| Condition                |  |         |
| Condition %              |  |         |
| Percent Good             |  | 84      |
| RCNLD                    |  | 755,800 |
| Dep % Ovr                |  |         |
| Dep Ovr Comment          |  |         |
| Misc Imp Ovr             |  |         |
| Misc Imp Ovr Comment     |  |         |
| Cost to Cure Ovr         |  |         |
| Cost to Cure Ovr Comment |  |         |

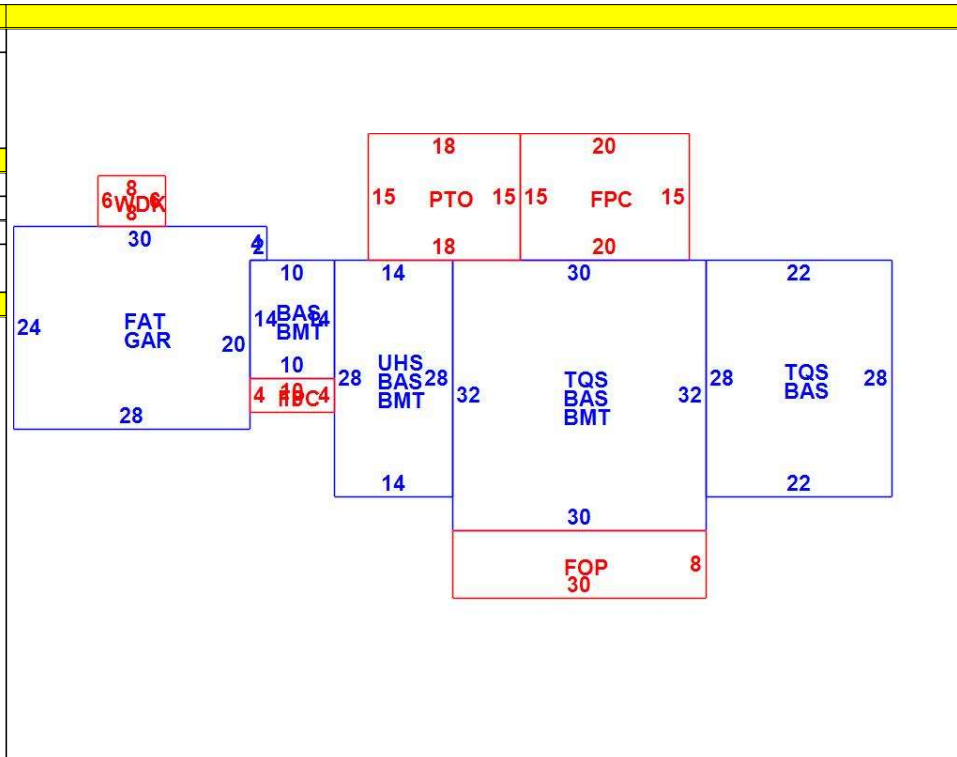

| OB - OUTBUILDING & YARD ITEMS(L) / XF - BUILDING EXTRA FEATURES(B) |                 |     |       |            |        |          |      |       |            |             |
|--|-----------------|-----|-------|------------|--------|----------|------|-------|------------|-------------|
| Code   | Description     | L/B | Units | Unit Price | Yr Blt | Cond. Cd | % Gd | Grade | Grade Adj. | Appr. Value |
| FPL2   | Fireplace 1.5 s | B   | 1     | 6000.00    | 2001   |          | 84   |       | 0.00       | 5,000       |
| FPO  | Ext FP Openin   | B   | 1     | 2000.00    | 2001   |          | 84   |       | 0.00       | 1,700       |
| BFA  | Bsmt Fin-Avg    | B   | 836   | 17.36      | 2001   |          | 84   |       | 0.00       | 12,200      |
| FOPC   | Open Prch-roo   | B   | 340   | 55.00      | 2001   |          | 84   |       | 0.00       | 10,900      |
| GAR  | Attached Gara   | B   | 680   | 40.00      | 2001   |          | 84   |       | 0.00       | 19,300      |
| BMT  | Basement-Unfi   | B   | 1,492 | 26.01      | 2001   |          | 84   |       | 0.00       | 29,700      |
| SOL2   | Solar PV Pane   | B   | 32    | 725.00     | 2001   |          | 0    |       | 0.00       | 0           |
| PATC   | Conc Pavers     | L   | 270   | 15.46      | 1998   |          | 79   |       | 0.00       | 3,400       |
| WDC  | Wood Decking    | L   | 48    | 20.00      | 1998   |          | 58   |       | 0.00       | 1,600       |
| SHED   | Shed            | L   | 120   | 18.00      | 1999   |          | 60   |       | 0.00       | 1,300       |

| BUILDING SUB-AREA SUMMARY SECTION |                        |             |            |          |           |                |
|-----------------------------------|------------------------|-------------|------------|----------|-----------|----------------|
| Code                              | Description            | Living Area | Floor Area | Eff Area | Unit Cost | Undeprec Value |
| BAS                               | First Floor            | 2,108       | 2,108      | 2,108    | 268.41    | 565,810        |
| BMT                               | Basement Area          | 0           | 1,492      | 0        | 0.00      | 0              |
| FAT                               | Attic, Finished        | 102         | 680        | 102      | 40.26     | 27,378         |
| FOP                               | Open Porch             | 0           | 240        | 0        | 0.00      | 0              |
| FPC                               | Open Porch Conc. Floor | 0           | 340        | 0        | 0.00      | 0              |
| GAR                               | Attached Garage        | 0           | 680        | 0        | 0.00      | 0              |
| PTO                               | Patio                  | 0           | 270        | 0        | 0.00      | 0              |
| TQS                               | Three Quarter Story    | 1,024       | 1,576      | 1,024    | 174.40    | 274,853        |
| UHS                               | Half Story, Unfinished | 0           | 392        | 118      | 80.80     | 31,672         |
| WDK                               | Wood Deck              | 0           | 48         | 0        | 0.00      | 0              |
| Ttl Gross Liv / Lease Area        |                        | 3,234       | 7,826      | 3,352    |           | 899,713        |



| CURRENT OWNER   |            | TOPO        | UTILITIES         | STRT / ROAD      | LOCATION               | CURRENT ASSESSMENT |           |   |            | 801<br>FY2025<br>BARNSTABLE, MA<br><br><b>VISION</b> |           |           |           |                    |                |            |
|---|------------|-------------|-------------------|------------------|------------------------|--------------------|-----------|---|------------|--|-----------|-----------|-----------|--------------------|----------------|------------|
| ST MARY, CHRISTOPHER & JASON T<br>MICHAEL & KATHERINE ST MARY IR<br>113 MISTIC DRIVE<br><br>MARSTONS MIL MA 02648 |            | 1 Level     | 6 Septic          | 1 Paved          |                        | Description        | Code      | Assessed  | Assessed   |  |           |           |           |                    |                |            |
|   |            |             | 4 Gas             |                  |                        | RESIDNTL           | 1010      | 849,400   | 849,400    |  |           |           |           |                    |                |            |
|   |            |             | 2 Public Water    |                  | 6                      | RES LAND           | 1010      | 247,500   | 247,500    |  |           |           |           |                    |                |            |
| <b>SUPPLEMENTAL DATA</b>  |            |             |                   |                  |                        | Total              |           |   |            | 1,096,900  | 1,096,900 |           |           |                    |                |            |
| Alt Prcl ID   |            | Split Zonin |                   | Plan Ref. 203/53 |                        |                    |           |   |            |  |           |           |           |                    |                |            |
| BID Parcel  |            | ResExpt Q   |                   | Land Ct#         |                        |                    |           |   |            |  |           |           |           |                    |                |            |
| #DL 1 LOT 52  |            | #DL 2       |                   | #SR              |                        |                    |           |   |            |  |           |           |           |                    |                |            |
| GIS ID F_953429_2703689   |            | Assoc Pid#  |                   | Life Estate      |                        |                    |           |   |            |  |           |           |           |                    |                |            |
| PP STATU  |            |             |                   |                  |                        |                    |           |   |            |  |           |           |           |                    |                |            |
| RECORD OF OWNERSHIP   |            | BK-VOL/PAGE | SALE DATE         | Q/U              | V/I                    | SALE PRIC          | VC        | PREVIOUS ASSESSMENTS (HISTORY)                                      |            |  |           |           |           |                    |                |            |
|   |            |             |                   |                  |                        |                    |           | Year  | Code       | Assessed   | Year      | Code      | Assessed  | Year               | Code           | Assessed   |
|   |            |             |                   |                  |                        |                    |           | 2025  | 1010       | 849,400  | 2024      | 1010      | 795,000   | 2023               | 1010           | 697,700    |
|   |            |             |                   |                  |                        |                    |           |   | 1010       | 247,500  |           | 1010      | 247,500   |                    | 1010           | 225,000    |
|   |            |             |                   |                  |                        |                    |           | Total   |            | 1,096,900  | Total     |           | 1,042,500 | Total              |                | 922,700    |
| EXEMPTIONS  |            |             | OTHER ASSESSMENTS |                  |                        |                    |           | This signature acknowledges a visit by a Data Collector or Assessor |            |  |           |           |           |                    |                |            |
| Year  | Code       | Description | Amount            | Code             | Description            | Number             | Amount    | Comm Int  |            |  |           |           |           |                    |                |            |
|   |            |             |                   |                  |                        |                    |           |   |            |  |           |           |           |                    |                |            |
|   |            |             |                   |                  |                        |                    |           |   |            |  |           |           |           |                    |                |            |
|   |            | Total       |                   |                  |                        |                    |           |   |            |  |           |           |           |                    |                |            |
| ASSESSING NEIGHBORHOOD  |            |             |                   |                  |                        |                    |           |   |            | APPRAISED VALUE SUMMARY                              |           |           |           |                    |                |            |
| Nbhd  | Nbhd Name  |             | B                 | Tracing          |                        | Batch              |           |   |            |  |           |           |           |                    |                |            |
| 0108  |            |             |                   |                  |                        | MARSTM             |           |   |            |  |           |           |           |                    |                |            |
| NOTES   |            |             |                   |                  |                        |                    |           |   |            |  |           |           |           |                    |                |            |
|   |            |             |                   |                  |                        |                    |           |   |            |  |           |           |           |                    |                |            |
|   |            |             |                   |                  |                        |                    |           |   |            |  |           |           |           |                    |                |            |
|   |            |             |                   |                  |                        |                    |           |   |            |  |           |           |           |                    |                |            |
| BUILDING PERMIT RECORD  |            |             |                   |                  |                        |                    |           |   |            | VISIT / CHANGE HISTORY                               |           |           |           |                    |                |            |
| Permit Id   | Issue Date | Type        | Description       | Amount           | Insp Date              | % Comp             | Date Comp | Comments  |            | Date   | Id        | Type      | Is        | Cd                 | Purpost/Result |            |
|   |            |             |                   |                  |                        |                    |           |   |            |  |           |           |           |                    |                |            |
|   |            |             |                   |                  |                        |                    |           |   |            |  |           |           |           |                    |                |            |
| LAND LINE VALUATION SECTION   |            |             |                   |                  |                        |                    |           |   |            |  |           |           |           |                    |                |            |
| B   | Use Code   | Description | Zone              | LA               | Land Units             | Unit Price         | Size Adj  | AC Disc   | Site Index | Cond.  | Nbhd.     | Nbhd. Adj | Notes     | Location Adjustmen | Adj Unit P     | Land Value |
|   |            |             |                   |                  |                        |                    |           |   |            |  |           |           |           |                    |                |            |
|   |            |             |                   |                  |                        |                    |           |   |            |  |           |           |           |                    |                |            |
| Total Card Land Units   |            |             |                   |                  | Parcel Total Land Area |                    |           |   |            | Total Land Value                                     |           |           |           |                    |                |            |

| CONSTRUCTION DETAIL   |               |                |            |             |           | CONSTRUCTION DETAIL (CONTINUED) |      |             |            |             |  |
|---|---------------|----------------|------------|-------------|-----------|---------------------------------|------|-------------|------------|-------------|--|
| Element   | Cd            | Description    |            |             |           | Element                         | Cd   | Description |            |             |  |
| Style   | 04            | Cape Cod       |            |             |           |                                 |      |             |            |             |  |
| Model   | 01            | Residential    |            |             |           |                                 |      |             |            |             |  |
| Grade:  | C+            | Average Plus   |            |             |           |                                 |      |             |            |             |  |
| Stories   | 1.75          | 1 3/4 Stories  |            |             |           |                                 |      |             |            |             |  |
| Exterior Wall 1   | 14            | Wood Shingle   |            |             |           |                                 |      |             |            |             |  |
| Exterior Wall 2   | 11            | Clapboard      |            |             |           |                                 |      |             |            |             |  |
| Roof Structure  | 03            | Gable/Hip      |            |             |           |                                 |      |             |            |             |  |
| Roof Cover  | 03            | Asph/F Gls/Cmp |            |             |           |                                 |      |             |            |             |  |
| Interior Wall 1   | 03            | Plastered      |            |             |           |                                 |      |             |            |             |  |
| Interior Wall 2   |               |                |            |             |           |                                 |      |             |            |             |  |
| Interior Floor 1  | 14            | Carpet         |            |             |           |                                 |      |             |            |             |  |
| Interior Floor 2  | 12            | Hardwood       |            |             |           |                                 |      |             |            |             |  |
| Heat Fuel   | 03            | Gas            |            |             |           |                                 |      |             |            |             |  |
| Heat Type   | 05            | Hot Water      |            |             |           |                                 |      |             |            |             |  |
| AC Type   | 03            | Central        |            |             |           |                                 |      |             |            |             |  |
| Bedrooms  | 05            | 5 Bedrooms     |            |             |           |                                 |      |             |            |             |  |
| Full Baths  | 3             |                |            |             |           |                                 |      |             |            |             |  |
| Half Baths  | 1             |                |            |             |           |                                 |      |             |            |             |  |
| Extra Fixtures  |               |                |            |             |           |                                 |      |             |            |             |  |
| Total Rooms   | 8             |                |            |             |           |                                 |      |             |            |             |  |
| Bath Style  |               |                |            |             |           |                                 |      |             |            |             |  |
| Kitchen Style   |               |                |            |             |           |                                 |      |             |            |             |  |
| Occupancy   |               |                |            |             |           |                                 |      |             |            |             |  |
| Sewer Occupan   |               |                |            |             |           |                                 |      |             |            |             |  |
| Accessory Apt   |               |                |            |             |           |                                 |      |             |            |             |  |
| Foundation Alt  | 01            | Poured Conc.   |            |             |           |                                 |      |             |            |             |  |
| Rms Prts  |               |                |            |             |           |                                 |      |             |            |             |  |
| Bath Split  | 31            | 3 Full-1 Half  |            |             |           |                                 |      |             |            |             |  |
| <b>CONDO DATA</b>   |               |                |            |             |           |                                 |      |             |            |             |  |
| Parcel Id   |               |                |            | C           |           | Owne                            |      | 0.0         |            |             |  |
| Adjust Type   |               | Code           |            | Description |           | Factor%                         |      |             |            |             |  |
| Condo Flr   |               |                |            |             |           |                                 |      |             |            |             |  |
| Condo Unit  |               |                |            |             |           |                                 |      |             |            |             |  |
| <b>COST / MARKET VALUATION</b>  |               |                |            |             |           |                                 |      |             |            |             |  |
| Building Value New  |               |                |            |             |           |                                 |      |             |            |             |  |
| Year Built  |               |                |            |             |           |                                 |      |             |            |             |  |
| Effective Year Built  |               |                |            |             |           |                                 |      |             |            |             |  |
| Depreciation Code   |               |                |            |             |           |                                 |      |             |            |             |  |
| Remodel Rating  |               |                |            |             |           |                                 |      |             |            |             |  |
| Year Remodeled  |               |                |            |             |           |                                 |      |             |            |             |  |
| Depreciation %  |               |                |            |             |           |                                 |      |             |            |             |  |
| Functional Obsol  |               |                |            |             |           |                                 |      |             |            |             |  |
| External Obsol  |               |                |            |             |           |                                 |      |             |            |             |  |
| Trend Factor  |               |                |            |             |           |                                 |      |             |            |             |  |
| Condition   |               |                |            |             |           |                                 |      |             |            |             |  |
| Condition %   |               |                |            |             |           |                                 |      |             |            |             |  |
| Percent Good  |               |                |            |             |           |                                 |      |             |            |             |  |
| RCNLD   |               |                |            |             |           |                                 |      |             |            |             |  |
| Dep % Ovr   |               |                |            |             |           |                                 |      |             |            |             |  |
| Dep Ovr Comment   |               |                |            |             |           |                                 |      |             |            |             |  |
| Misc Imp Ovr  |               |                |            |             |           |                                 |      |             |            |             |  |
| Misc Imp Ovr Comment  |               |                |            |             |           |                                 |      |             |            |             |  |
| Cost to Cure Ovr  |               |                |            |             |           |                                 |      |             |            |             |  |
| Cost to Cure Ovr Comment  |               |                |            |             |           |                                 |      |             |            |             |  |
| <b>OB - OUTBUILDING &amp; YARD ITEMS(L) / XF - BUILDING EXTRA FEATURES(B)</b> |               |                |            |             |           |                                 |      |             |            |             |  |
| Code  | Description   | L/B            | Units      | Unit Price  | Yr Blt    | Cond. Cd                        | % Gd | Grade       | Grade Adj. | Appr. Value |  |
| SOLT  | Solar Thermal | B              | 72         | 86.00       | 2001      |                                 | 0    |             | 0.00       | 0           |  |
| FOP   | Open Porch-ro | B              | 240        | 55.00       | 2001      |                                 | 84   |             | 0.00       | 8,500       |  |
| <b>BUILDING SUB-AREA SUMMARY SECTION</b>                                      |               |                |            |             |           |                                 |      |             |            |             |  |
| Code  | Description   | Living Area    | Floor Area | Eff Area    | Unit Cost | Undeprec Value                  |      |             |            |             |  |
|   |               |                |            |             |           |                                 |      |             |            |             |  |
| Ttl Gross Liv / Lease Area  |               |                |            |             |           |                                 |      |             |            |             |  |