

| CURRENT OWNER  |  | TOPO    | UTILITIES      | STRT / ROAD  | LOCATION | CURRENT ASSESSMENT |      |          |          | 801<br>FY2025<br>BARNSTABLE, MA<br><br><b>VISION</b> |           |
|--|--|---------|----------------|--|----------|--------------------|------|----------|----------|--|-----------|
| BRODEUR, DEBORAH M<br><br>185 MISTIC DRIVE<br><br>MARSTONS MIL MA 02648  |  | 1 Level | 2 Public Water | 1 Paved  |          | Description        | Code | Assessed | Assessed |  |           |
|  |  |         | 4 Gas          |  |          | RESIDENTL          | 1010 | 768,100  | 768,100  |  |           |
|  |  |         | 6 Septic       |  | 6        | RES LAND           | 1010 | 247,300  | 247,300  |  |           |
| <b>SUPPLEMENTAL DATA</b>   |  |         |                |  |          | Total              |      |          |          | 1,015,400  | 1,015,400 |
| Alt Prcl ID<br>Split Zonin<br>BID Parcel<br>ResExpt Q YES:<br>#DL 1 LOT 47<br>#DL 2<br>GIS ID F_952712_2704124 |  |         |                | Plan Ref. 203/53<br>Land Ct#<br>#SR<br>Life Estate<br>PP STATU<br>Assoc Pid# |          |                    |      |          |          |  |           |

| RECORD OF OWNERSHIP           |  | BK-VOL/PAGE | SALE DATE  | Q/U | V/I | SALE PRIC | VC | PREVIOUS ASSESSMENTS (HISTORY) |       |          |           |       |          |         |      |          |
|-------------------------------|--|-------------|------------|-----|-----|-----------|----|--------------------------------|-------|----------|-----------|-------|----------|---------|------|----------|
| BRODEUR, DEBORAH M            |  | 28604 0311  | 12-30-2014 | U   | I   | 450,000   | 1  | Year                           | Code  | Assessed | Year      | Code  | Assessed | Year    | Code | Assessed |
| RILEY, JOHN C & MARK TRS      |  | 28604 0309  | 12-30-2014 | U   | I   | 0         | 1F | 2025                           | 1010  | 768,100  | 2024      | 1010  | 765,400  | 2023    | 1010 | 674,800  |
| RILEY, JOHN P JR & JOHN C TRS |  | 24938 0107  | 10-26-2010 | U   | I   | 1         | 1F |                                | 1010  | 247,300  |           | 1010  | 247,300  |         | 1010 | 224,800  |
| RILEY, JOHN P                 |  | 8056 0112   | 06-15-1992 | U   | I   | 1         | F  |                                |       |          |           |       |          |         |      |          |
| RILEY, JOHN P & MAUREEN T     |  | 4074 0191   | 04-15-1984 | U   | V   | 25,000    | Z  |                                |       |          |           |       |          |         |      |          |
| Total                         |  |             |            |     |     |           |    | 1,015,400                      | Total |          | 1,012,700 | Total |          | 899,600 |      |          |

| EXEMPTIONS |      |                       |        | OTHER ASSESSMENTS |             |        |        | This signature acknowledges a visit by a Data Collector or Assessor |  |  |  |  |  |  |  |  |  |  |
|------------|------|-----------------------|--------|-------------------|-------------|--------|--------|---|--|--|--|--|--|--|--|--|--|--|
| Year       | Code | Description           | Amount | Code              | Description | Number | Amount | Comm Int  |  |  |  |  |  |  |  |  |  |  |
| 2019       | 5C   | RESIDENTIAL EXEMPTION | 0.00   |                   |             |        |        |   |  |  |  |  |  |  |  |  |  |  |
| Total      |      |                       | 0.00   |                   |             |        |        |   |  |  |  |  |  |  |  |  |  |  |

| ASSESSING NEIGHBORHOOD |           |   |         | APPRAISED VALUE SUMMARY |  |  |  |  |
|------------------------|-----------|---|---------|-------------------------|--|--|--|--|
| Nbhd                   | Nbhd Name | B | Tracing | Batch                   |  |  |  |  |
| 0108                   |           |   | MARSTM  |                         |  |  |  |  |

| NOTES |  |  |  |  |  |  |  |  |  | APPRAISED VALUE SUMMARY       |  |  |  |  |  |           |
|-------|--|--|--|--|--|--|--|--|--|-------------------------------|--|--|--|--|--|-----------|
|       |  |  |  |  |  |  |  |  |  | Appraised Bldg. Value (Card)  |  |  |  |  |  | 577,500   |
|       |  |  |  |  |  |  |  |  |  | Appraised Xf (B) Value (Bldg) |  |  |  |  |  | 131,600   |
|       |  |  |  |  |  |  |  |  |  | Appraised Ob (B) Value (Bldg) |  |  |  |  |  | 59,000    |
|       |  |  |  |  |  |  |  |  |  | Appraised Land Value (Bldg)   |  |  |  |  |  | 247,300   |
|       |  |  |  |  |  |  |  |  |  | Special Land Value            |  |  |  |  |  | 0         |
|       |  |  |  |  |  |  |  |  |  | Total Appraised Parcel Value  |  |  |  |  |  | 1,015,400 |
|       |  |  |  |  |  |  |  |  |  | Valuation Method              |  |  |  |  |  | C         |
|       |  |  |  |  |  |  |  |  |  | Total Appraised Parcel Value  |  |  |  |  |  | 1,015,400 |

| BUILDING PERMIT RECORD |            |      |                 |         |            |        |            |                                   |            | VISIT / CHANGE HISTORY |      |    |    |                       |  |
|------------------------|------------|------|-----------------|---------|------------|--------|------------|-----------------------------------|------------|------------------------|------|----|----|-----------------------|--|
| Permit Id              | Issue Date | Type | Description     | Amount  | Insp Date  | % Comp | Date Comp  | Comments                          | Date       | Id                     | Type | Is | Cd | Purpost/Result        |  |
| BLDR-21-14             | 11-22-2021 | 839  | Solar Panel-Re  | 25,740  | 03-02-2022 | 100    | 06-30-2022 | Installation of roof mounted ph   | 09-02-2022 | CK                     | 03   |    | 16 | In Office Review      |  |
| 20-2416                | 09-09-2020 | 830  | Pool - Inground | 119,900 | 12-07-2020 | 100    | 06-30-2021 | Installation of 8'x30' Gunite swi | 12-07-2020 | SR                     | 02   |    | 02 | Bldg Permit Completed |  |
| 201504806              | 08-04-2015 | AD   | Addition        | 20,000  | 03-17-2016 | 100    | 06-30-2016 | TO BUILD A THREE SEASON           | 05-12-2020 | LS                     |      |    | FR | Field Review          |  |
| 201504104              | 07-17-2015 | FB   | Finish Basemen  | 30,000  | 03-17-2016 | 100    | 06-30-2016 | finish basement add full bath     | 03-21-2019 | JD                     | 03   |    | 16 | In Office Review      |  |
| 201500310              | 01-29-2015 | RE   | Remodel         | 68,000  | 07-15-2015 | 100    | 06-30-2015 | NEW ANDERSON WINDOW,              | 03-24-2016 | SR                     | 02   |    | 02 | Bldg Permit Completed |  |
| B26266                 | 04-01-1984 | DW   | Dwelling        | 0       | 04-15-1985 | 100    | 12-31-1985 | MM 1 STOR                         | 08-13-2015 | JR                     | 03   |    | 20 | Sale Review           |  |
|                        |            |      |                 |         |            |        |            |                                   |            | 07-21-2015             | SR   | 02 | 02 | Bldg Permit Completed |  |

| LAND LINE VALUATION SECTION |          |                |      |    |            |            |                        |         |            |       |       |           |                  |                    |            |            |         |
|-----------------------------|----------|----------------|------|----|------------|------------|------------------------|---------|------------|-------|-------|-----------|------------------|--------------------|------------|------------|---------|
| B                           | Use Code | Description    | Zone | LA | Land Units | Unit Price | Size Adj               | AC Disc | Site Index | Cond. | Nbhd. | Nbhd. Adj | Notes            | Location Adjustmen | Adj Unit P | Land Value |         |
| 1                           | 1010     | Single Fam M-0 | RF   | 3  | 1.000      | AC         | 176,344.00             | 1.00000 | 1.0000     | 5     | 1.00  | 0107      | 1.400            |                    | 1.0000     | 246,881.6  | 246,900 |
| 1                           | 1010     | Single Fam M-0 | RF   | 3  | 0.020      | AC         | 14,250.00              | 1.00000 | 1.0000     | 0     | 1.00  | 0107      | 1.400            |                    | 1.0000     | 19,950     | 400     |
| Total Card Land Units       |          |                |      |    | 1.02       | AC         | Parcel Total Land Area |         |            |       |       | 1.02      | Total Land Value |                    |            | 247,300    |         |

| CONSTRUCTION DETAIL |    |                | CONSTRUCTION DETAIL (CONTINUED) |    |             |
|---------------------|----|----------------|---------------------------------|----|-------------|
| Element             | Cd | Description    | Element                         | Cd | Description |
| Style               | 01 | Ranch          |                                 |    |             |
| Model               | 01 | Residential    |                                 |    |             |
| Grade:              | C+ | Average Plus   |                                 |    |             |
| Stories             | 1  | 1 Story        |                                 |    |             |
| Exterior Wall 1     | 14 | Wood Shingle   |                                 |    |             |
| Exterior Wall 2     |    |                |                                 |    |             |
| RooF Structure      | 03 | Gable/Hip      |                                 |    |             |
| RooF Cover          | 03 | Asph/F Gls/Cmp |                                 |    |             |
| Interior Wall 1     | 03 | Plastered      |                                 |    |             |
| Interior Wall 2     |    |                |                                 |    |             |
| Interior Floor 1    | 12 | Hardwood       |                                 |    |             |
| Interior Floor 2    |    |                |                                 |    |             |
| Heat Fuel           | 03 | Gas            |                                 |    |             |
| Heat Type           | 04 | Hot Air        |                                 |    |             |
| AC Type             | 03 | Central        |                                 |    |             |
| Bedrooms            | 03 | 3 Bedrooms     |                                 |    |             |
| Full Baths          | 2  |                |                                 |    |             |
| Half Baths          | 1  |                |                                 |    |             |
| Extra Fixtures      |    |                |                                 |    |             |
| Total Rooms         | 8  | 8 Rooms        |                                 |    |             |
| Bath Style          |    |                |                                 |    |             |
| Kitchen Style       |    |                |                                 |    |             |
| Occupancy           |    |                |                                 |    |             |
| Sewer Occupan       |    |                |                                 |    |             |
| Accessory Apt       |    |                |                                 |    |             |
| Foundation Alt      | 01 | Poured Conc.   |                                 |    |             |
| Rms Prts            |    |                |                                 |    |             |
| Bath Split          | 21 | 2 Full-1 Half  |                                 |    |             |

| CONDO DATA               |      |             |         |
|--------------------------|------|-------------|---------|
| Parcel Id                | C    | Ownr        | 0.0     |
| Adjust Type              | Code | Description | Factor% |
| Condo Flr                |      |             |         |
| Condo Unit               |      |             |         |
| COST / MARKET VALUATION  |      |             |         |
| Building Value New       |      | 663,755     |         |
| Year Built               |      | 1984        |         |
| Effective Year Built     |      | 2007        |         |
| Depreciation Code        |      | G           |         |
| Remodel Rating           |      |             |         |
| Year Remodeled           |      |             |         |
| Depreciation %           |      | 13          |         |
| Functional Obsol         |      | 0           |         |
| External Obsol           |      | 0           |         |
| Trend Factor             |      | 1           |         |
| Condition                |      |             |         |
| Condition %              |      |             |         |
| Percent Good             |      | 87          |         |
| RCNLD                    |      | 577,500     |         |
| Dep % Ovr                |      |             |         |
| Dep Ovr Comment          |      |             |         |
| Misc Imp Ovr             |      |             |         |
| Misc Imp Ovr Comment     |      |             |         |
| Cost to Cure Ovr         |      |             |         |
| Cost to Cure Ovr Comment |      |             |         |

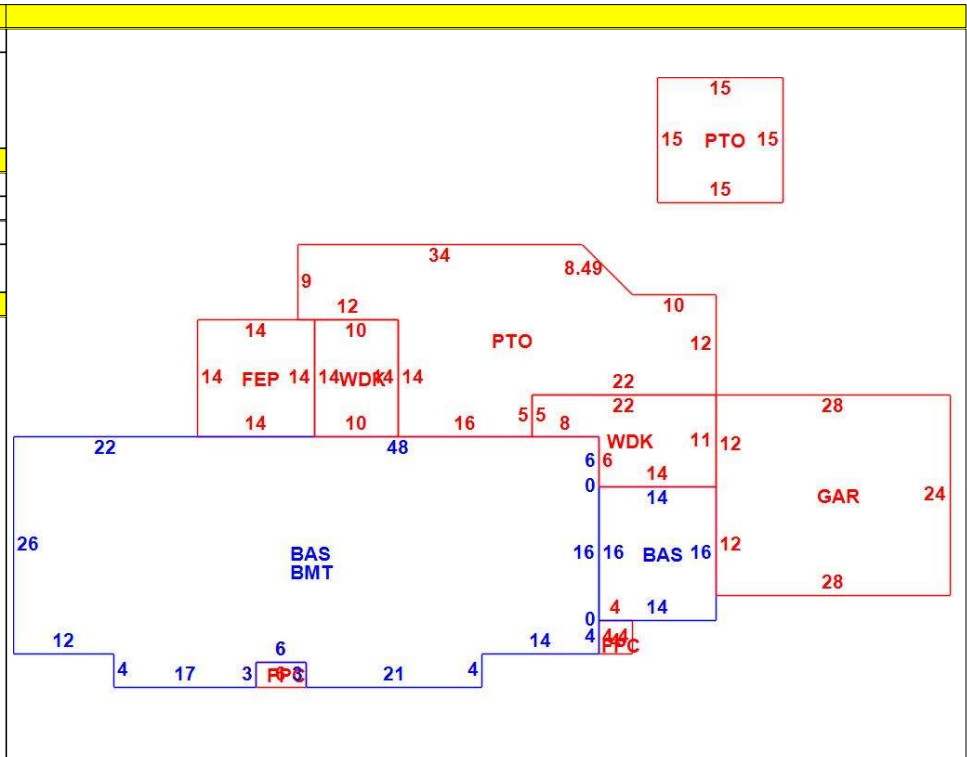

**OB - OUTBUILDING & YARD ITEMS(L) / XF - BUILDING EXTRA FEATURES(B)**

| Code | Description     | L/B | Units | Unit Price | Yr Blt | Cond. Cd | % Gd | Grade | Grade Adj. | Appr. Value |
|------|-----------------|-----|-------|------------|--------|----------|------|-------|------------|-------------|
| FPL1 | Fireplace 1 sto | B   | 1     | 5000.00    | 2005   |          | 87   |       | 0.00       | 4,400       |
| FOPC | Open Prch-roo   | B   | 34    | 55.00      | 2005   |          | 87   |       | 0.00       | 1,900       |
| GAR  | Attached Gara   | B   | 672   | 40.00      | 2005   |          | 87   |       | 0.00       | 19,900      |
| BMT  | Basement-Unfi   | B   | 1,978 | 26.01      | 2005   |          | 87   |       | 0.00       | 38,600      |
| WDC  | Wood Deck w/    | L   | 194   | 18.00      | 2015   |          | 92   |       | 0.00       | 3,900       |
| WDC  | Wood Deck w/    | L   | 140   | 18.00      | 2015   |          | 92   |       | 0.00       | 3,300       |
| PAT2 | Patio-Good      | L   | 1,019 | 9.94       | 2015   |          | 96   |       | 0.00       | 8,700       |
| FEP  | Enclosed porc   | B   | 196   | 70.00      | 2005   |          | 87   |       | 0.00       | 10,800      |
| BFA1 | Bsmt Fin-Goo    | B   | 1,978 | 32.56      | 2005   |          | 87   |       | 0.00       | 56,000      |
| FPIT | Fire Pit        | L   | 1     | 3010.00    | 2015   |          | 91   | C     | 1.00       | 2,700       |

**BUILDING SUB-AREA SUMMARY SECTION**

| Code                       | Description            | Living Area | Floor Area | Eff Area | Unit Cost | Undeprec Value |
|----------------------------|------------------------|-------------|------------|----------|-----------|----------------|
| BAS                        | First Floor            | 2,202       | 2,202      | 2,202    | 301.43    | 663,755        |
| BMT                        | Basement Area          | 0           | 1,978      | 0        | 0.00      | 0              |
| FEP                        | Enclosed Porch         | 0           | 196        | 0        | 0.00      | 0              |
| FPC                        | Open Porch Conc. Floor | 0           | 34         | 0        | 0.00      | 0              |
| GAR                        | Attached Garage        | 0           | 672        | 0        | 0.00      | 0              |
| PTO                        | Patio                  | 0           | 1,019      | 0        | 0.00      | 0              |
| WDC                        | Wood Deck              | 0           | 334        | 0        | 0.00      | 0              |
| Ttl Gross Liv / Lease Area |                        | 2,202       | 6,435      | 2,202    |           | 663,755        |



| CURRENT OWNER   |            | TOPO           | UTILITIES         | STRT / ROAD      | LOCATION               | CURRENT ASSESSMENT      |           |   |            | 801<br>FY2025<br>BARNSTABLE, MA<br><br><b>VISION</b> |           |           |           |                    |            |            |
|---|------------|----------------|-------------------|------------------|------------------------|-------------------------|-----------|---|------------|--|-----------|-----------|-----------|--------------------|------------|------------|
| BRODEUR, DEBORAH M<br><br>185 MISTIC DRIVE<br><br>MARSTONS MIL MA 02648 |            | 1 Level        | 2 Public Water    | 1 Paved          |                        | Description             | Code      | Assessed  | Assessed   |  |           |           |           |                    |            |            |
|   |            |                | 4 Gas             |                  |                        | RESIDNTL                | 1010      | 768,100   | 768,100    |  |           |           |           |                    |            |            |
|   |            |                | 6 Septic          |                  | 6                      | RES LAND                | 1010      | 247,300   | 247,300    |  |           |           |           |                    |            |            |
| <b>SUPPLEMENTAL DATA</b>  |            |                |                   |                  |                        | Total                   |           |   |            | 1,015,400  | 1,015,400 |           |           |                    |            |            |
| Alt Prcl ID   |            | Split Zonin    |                   | Plan Ref. 203/53 |                        |                         |           |   |            |  |           |           |           |                    |            |            |
| BID Parcel  |            | ResExpt Q YES: |                   | Land Ct#         |                        |                         |           |   |            |  |           |           |           |                    |            |            |
| #DL 1 LOT 47  |            | #DL 2          |                   | Life Estate      |                        |                         |           |   |            |  |           |           |           |                    |            |            |
| GIS ID F_952712_2704124   |            | Assoc Pid#     |                   | PP STATU         |                        |                         |           |   |            |  |           |           |           |                    |            |            |
| RECORD OF OWNERSHIP   |            | BK-VOL/PAGE    | SALE DATE         | Q/U              | V/I                    | SALE PRIC               | VC        | PREVIOUS ASSESSMENTS (HISTORY)                                      |            |  |           |           |           |                    |            |            |
|   |            |                |                   |                  |                        |                         |           | Year  | Code       | Assessed   | Year      | Code      | Assessed  | Year               | Code       | Assessed   |
|   |            |                |                   |                  |                        |                         |           | 2025  | 1010       | 768,100  | 2024      | 1010      | 765,400   | 2023               | 1010       | 674,800    |
|   |            |                |                   |                  |                        |                         |           |   | 1010       | 247,300  |           | 1010      | 247,300   |                    | 1010       | 224,800    |
|   |            |                |                   |                  |                        |                         |           | Total   |            | 1,015,400  | Total     |           | 1,012,700 | Total              |            | 899,600    |
| EXEMPTIONS  |            |                | OTHER ASSESSMENTS |                  |                        |                         |           | This signature acknowledges a visit by a Data Collector or Assessor |            |  |           |           |           |                    |            |            |
| Year  | Code       | Description    | Amount            | Code             | Description            | Number                  | Amount    | Comm Int  |            |  |           |           |           |                    |            |            |
|   |            |                |                   |                  |                        |                         |           |   |            |  |           |           |           |                    |            |            |
|   |            | Total          |                   |                  |                        |                         |           |   |            |  |           |           |           |                    |            |            |
| ASSESSING NEIGHBORHOOD  |            |                |                   |                  |                        | APPRAISED VALUE SUMMARY |           |   |            |  |           |           |           |                    |            |            |
| Nbhd  | Nbhd Name  |                | B                 | Tracing          |                        | Batch                   |           | Appraised Bldg. Value (Card)  |            |  |           | 577,500   |           |                    |            |            |
| 0108  |            |                |                   |                  |                        | MARSTM                  |           | Appraised Xf (B) Value (Bldg)                                       |            |  |           | 131,600   |           |                    |            |            |
|   |            |                |                   |                  |                        |                         |           | Appraised Ob (B) Value (Bldg)                                       |            |  |           | 59,000    |           |                    |            |            |
|   |            |                |                   |                  |                        |                         |           | Appraised Land Value (Bldg)   |            |  |           | 247,300   |           |                    |            |            |
|   |            |                |                   |                  |                        |                         |           | Special Land Value  |            |  |           | 0         |           |                    |            |            |
|   |            |                |                   |                  |                        |                         |           | Total Appraised Parcel Value  |            |  |           | 1,015,400 |           |                    |            |            |
|   |            |                |                   |                  |                        |                         |           | Valuation Method  |            |  |           | C         |           |                    |            |            |
|   |            |                |                   |                  |                        |                         |           | Total Appraised Parcel Value  |            |  |           | 1,015,400 |           |                    |            |            |
| BUILDING PERMIT RECORD  |            |                |                   |                  |                        |                         |           | VISIT / CHANGE HISTORY  |            |  |           |           |           |                    |            |            |
| Permit Id   | Issue Date | Type           | Description       | Amount           | Insp Date              | % Comp                  | Date Comp | Comments  | Date       | Id   | Type      | Is        | Cd        | Purpost/Result     |            |            |
|   |            |                |                   |                  |                        |                         |           |   |            |  |           |           |           |                    |            |            |
| LAND LINE VALUATION SECTION   |            |                |                   |                  |                        |                         |           |   |            |  |           |           |           |                    |            |            |
| B   | Use Code   | Description    | Zone              | LA               | Land Units             | Unit Price              | Size Adj  | AC Disc   | Site Index | Cond.  | Nbhd.     | Nbhd. Adj | Notes     | Location Adjustmen | Adj Unit P | Land Value |
|   |            |                |                   |                  |                        |                         |           |   |            |  |           |           |           |                    |            |            |
| Total Card Land Units   |            |                |                   |                  | Parcel Total Land Area |                         |           |   |            | Total Land Value                                     |           |           |           |                    |            |            |

| CONSTRUCTION DETAIL   |               |                |            |            |           | CONSTRUCTION DETAIL (CONTINUED) |      |             |            |             |     |
|---|---------------|----------------|------------|------------|-----------|---------------------------------|------|-------------|------------|-------------|-----|
| Element   | Cd            | Description    |            |            |           | Element                         | Cd   | Description |            |             |     |
| Style   | 01            | Ranch          |            |            |           |                                 |      |             |            |             |     |
| Model   | 01            | Residential    |            |            |           |                                 |      |             |            |             |     |
| Grade:  | C+            | Average Plus   |            |            |           |                                 |      |             |            |             |     |
| Stories   | 1             | 1 Story        |            |            |           |                                 |      |             |            |             |     |
| Exterior Wall 1   | 14            | Wood Shingle   |            |            |           | <b>CONDO DATA</b>               |      |             |            |             |     |
| Exterior Wall 2   |               |                |            |            |           | Parcel Id                       |      | C           |            | Owne        | 0.0 |
| Roof Structure  | 03            | Gable/Hip      |            |            |           |                                 |      | B           |            | S           |     |
| Roof Cover  | 03            | Asph/F Gls/Cmp |            |            |           | Adjust Type                     | Code | Description |            | Factor%     |     |
| Interior Wall 1   | 03            | Plastered      |            |            |           | Condo Flr                       |      |             |            |             |     |
| Interior Wall 2   |               |                |            |            |           | Condo Unit                      |      |             |            |             |     |
| Interior Floor 1  | 12            | Hardwood       |            |            |           | <b>COST / MARKET VALUATION</b>  |      |             |            |             |     |
| Interior Floor 2  |               |                |            |            |           | Building Value New              |      |             |            |             |     |
| Heat Fuel   | 03            | Gas            |            |            |           | Year Built                      |      |             |            |             |     |
| Heat Type   | 04            | Hot Air        |            |            |           | Effective Year Built            |      |             |            |             |     |
| AC Type   | 03            | Central        |            |            |           | Depreciation Code               |      |             |            |             |     |
| Bedrooms  | 03            | 3 Bedrooms     |            |            |           | Remodel Rating                  |      |             |            |             |     |
| Full Baths  | 2             |                |            |            |           | Year Remodeled                  |      |             |            |             |     |
| Half Baths  | 1             |                |            |            |           | Depreciation %                  |      |             |            |             |     |
| Extra Fixtures  |               |                |            |            |           | Functional Obsol                |      |             |            |             |     |
| Total Rooms   | 8             | 8 Rooms        |            |            |           | External Obsol                  |      |             |            |             |     |
| Bath Style  |               |                |            |            |           | Trend Factor                    |      |             |            |             |     |
| Kitchen Style   |               |                |            |            |           | Condition                       |      |             |            |             |     |
| Occupancy   |               |                |            |            |           | Condition %                     |      |             |            |             |     |
| Sewer Occupan   |               |                |            |            |           | Percent Good                    |      |             |            |             |     |
| Accessory Apt   |               |                |            |            |           | RCNLD                           |      |             |            |             |     |
| Foundation Alt  | 01            | Poured Conc.   |            |            |           | Dep % Ovr                       |      |             |            |             |     |
| Rms Prts  |               |                |            |            |           | Dep Ovr Comment                 |      |             |            |             |     |
| Bath Split  | 21            | 2 Full-1 Half  |            |            |           | Misc Imp Ovr                    |      |             |            |             |     |
|   |               |                |            |            |           | Misc Imp Ovr Comment            |      |             |            |             |     |
|   |               |                |            |            |           | Cost to Cure Ovr                |      |             |            |             |     |
|   |               |                |            |            |           | Cost to Cure Ovr Comment        |      |             |            |             |     |
| <b>OB - OUTBUILDING &amp; YARD ITEMS(L) / XF - BUILDING EXTRA FEATURES(B)</b> |               |                |            |            |           |                                 |      |             |            |             |     |
| Code  | Description   | L/B            | Units      | Unit Price | Yr Blt    | Cond. Cd                        | % Gd | Grade       | Grade Adj. | Appr. Value |     |
| SPL3  | Pool Gunite   | L              | 240        | 75.00      | 2020      |                                 | 92   | C           | 1.00       | 24,300      |     |
| SPC1  | Pool Cover-Au | L              | 240        | 17.53      | 2020      |                                 | 92   |             | 0.00       | 3,900       |     |
| SPH1  | Pool Heater < | L              | 1          | 2434.00    | 2020      |                                 | 92   |             | 0.00       | 2,200       |     |
| PAT2  | Patio-Good    | L              | 848        | 9.94       | 2020      |                                 | 96   |             | 0.00       | 7,400       |     |
| PRG1  | Pergola-Avg   | L              | 120        | 18.00      | 2015      |                                 | 82   | C           | 1.00       | 1,800       |     |
| SHED  | Shed          | L              | 96         | 18.00      | 1996      |                                 | 44   |             | 0.00       | 800         |     |
| SOL2  | Solar PV Pane | B              | 33         | 725.00     | 2005      |                                 | 0    |             | 0.00       | 0           |     |
| <b>BUILDING SUB-AREA SUMMARY SECTION</b>                                      |               |                |            |            |           |                                 |      |             |            |             |     |
| Code  | Description   | Living Area    | Floor Area | Eff Area   | Unit Cost | Undeprec Value                  |      |             |            |             |     |
|   |               |                |            |            |           |                                 |      |             |            |             |     |
| Ttl Gross Liv / Lease Area  |               |                |            |            |           |                                 |      |             |            |             |     |