

CURRENT OWNER		TOPO	UTILITIES	STRT / ROAD	LOCATION	CURRENT ASSESSMENT				801 FY2025 BARNSTABLE, MA VISION	
STAVROS, CHRISTOPHER TR 936 SEA VIEW REALTY TRUST 886 MAIN STREET OSTERVILLE MA 02655		1 Level	2 Public Water	1 Paved	7 Waterfront	Description	Code	Assessed	Assessed		
			4 Gas		1 Excel View	RESIDNTL	1010	5,306,500	5,306,500		
			6 Septic		7	RES LAND	1010	8,474,200	8,474,200		
SUPPLEMENTAL DATA						Total				13,780,700	13,780,700
		Alt Prcl ID Split Zonin BID Parcel ResExpt Q #DL 1 LOT 36 & 186 #DL 2 GIS ID F_957599_2684776		Plan Ref. Land Ct# 2664-98 #SR Life Estate PP STATU Assoc Pid#							

RECORD OF OWNERSHIP		BK-VOL/PAGE	SALE DATE	Q/U	V/I	SALE PRIC	VC	PREVIOUS ASSESSMENTS (HISTORY)									
STAVROS, CHRISTOPHER TR MATTISON, PETER D TR MATTISON, JOSEPH JR TR MATTISON, ELIZABETH M		C198228	0	09-20-2012	U	I	5,675,000	1	Year	Code	Assessed	Year	Code	Assessed	Year	Code	Assessed
		#D10237	0	01-13-2006	U	I	0	1F	2025	1010	5,306,500	2024	1010	5,253,200	2023	1010	4,618,400
		C152996	0	05-05-1999	U	I	10	1F		1010	8,474,200			8,474,200			7,752,800
		C53100	0	11-22-1971	U		0		Total		13,780,700	Total		13,727,400	Total		12,371,200

EXEMPTIONS			OTHER ASSESSMENTS					This signature acknowledges a visit by a Data Collector or Assessor										
Year	Code	Description	Amount	Code	Description	Number	Amount	Comm Int										
		Total	0.00															

ASSESSING NEIGHBORHOOD				APPRAISED VALUE SUMMARY										
Nbhd	Nbhd Name	B	Tracing	Batch										
WF13			OSTVIL											
NOTES														
Appraised Bldg. Value (Card) 4,037,700 Appraised Xf (B) Value (Bldg) 377,700 Appraised Ob (B) Value (Bldg) 891,100 Appraised Land Value (Bldg) 8,474,200 Special Land Value 0 Total Appraised Parcel Value 13,780,700 Valuation Method C Total Appraised Parcel Value 13,780,700														

BUILDING PERMIT RECORD									VISIT / CHANGE HISTORY						
Permit Id	Issue Date	Type	Description	Amount	Insp Date	% Comp	Date Comp	Comments	Date	Id	Type	Is	Cd	Purpost/Result	
16-1355	06-03-2016	804	Addn Alt-Res	45,000	04-14-2017	100	06-30-2017	PEDESTRIAN TUNNEL	06-05-2020	WD			FR	Field Review	
16-313	02-23-2016	832	Shd-Res 200sf	0	04-14-2017	100	06-30-2017	CONSTRUCTION OF A NEW	06-28-2017	SR	02		02	Bldg Permit Completed	
201500066	01-16-2015	PV	Solar PV Syste	176,000	04-07-2016	100	06-30-2016	INSTALLATION OF A 38.07 K	06-09-2016	SR	02		02	Bldg Permit Completed	
201407693	11-17-2014	SP	Swimming Pool	190,000	04-07-2016	100	06-30-2016	INSTALLATION OF 22X45 IN	04-11-2016	SR	02		13	CALL BACK	
201407329	10-22-2014	SH	Shed	225,000	04-07-2016	100	06-30-2016	CONSTRUCT A CABANA 588	07-23-2015	JR	03		16	In Office Review	
201406344	09-25-2014	DG	Detached Gara	365,000	04-02-2016	100	06-30-2016	DG W FULL BMT, 1/2 BTH AN	07-17-2015	SR	02		13	CALL BACK	
201304339	07-08-2013	DE	Demolish	5,000	10-22-2013	100	06-30-2014	DEMO GARAGE #2	06-05-2015	JR	03		16	In Office Review	

LAND LINE VALUATION SECTION																
B	Use Code	Description	Zone	LA	Land Units	Unit Price	Size Adj	AC Disc	Site Index	Cond.	Nbhd.	Nbhd. Adj	Notes	Location Adjustmen	Adj Unit P	Land Value
1	1010	Single Fam M-0	RF-1	3	1.000	AC 176,344.00	1.00000	1.0000	5	1.00	WF13	45.000		1.0000	7,935,480	7,935,500
1	1010	Single Fam M-0	RF-1	3	0.840	AC 14,250.00	1.00000	1.0000	0	1.00	WF13	45.000		1.0002	641,250	538,700
Total Card Land Units					1.84	AC	Parcel Total Land Area					1.84	Total Land Value			8,474,200

CONSTRUCTION DETAIL			CONSTRUCTION DETAIL (CONTINUED)		
Element	Cd	Description	Element	Cd	Description
Style	06	Conventional			
Model	01	Residential			
Grade:	X+	Exceptional PI			
Stories	1.4				
Exterior Wall 1	14	Wood Shingle			
Exterior Wall 2					
RooF Structure	03	Gable/Hip			
RooF Cover	01	Metal/Tin			
Interior Wall 1	05	Drywall			
Interior Wall 2					
Interior Floor 1	12	Hardwood			
Interior Floor 2					
Heat Fuel	03	Gas			
Heat Type	04	Hot Air			
AC Type	03	Central			
Bedrooms	04	4 Bedrooms			
Full Baths	5				
Half Baths	1				
Extra Fixtures					
Total Rooms	7				
Bath Style					
Kitchen Style					
Occupancy					
Sewer Occupan					
Accessory Apt					
Foundation Alt	01	Poured Conc.			
Rms Prts					
Bath Split	51	5 Full-1 Half			
CONDO DATA			COST / MARKET VALUATION		
Parcel Id		C	Ownr	0.0	
Adjust Type	Code	Description	Factor%		
Condo Flr					
Condo Unit					
Building Value New			4,295,407		
Year Built		2013			
Effective Year Built		2016			
Depreciation Code		A			
Remodel Rating					
Year Remodeled					
Depreciation %		6			
Functional Obsol		0			
External Obsol		0			
Trend Factor		1			
Condition					
Condition %					
Percent Good		94			
RCNLD		4,037,700			
Dep % Ovr					
Dep Ovr Comment					
Misc Imp Ovr					
Misc Imp Ovr Comment					
Cost to Cure Ovr					
Cost to Cure Ovr Comment					

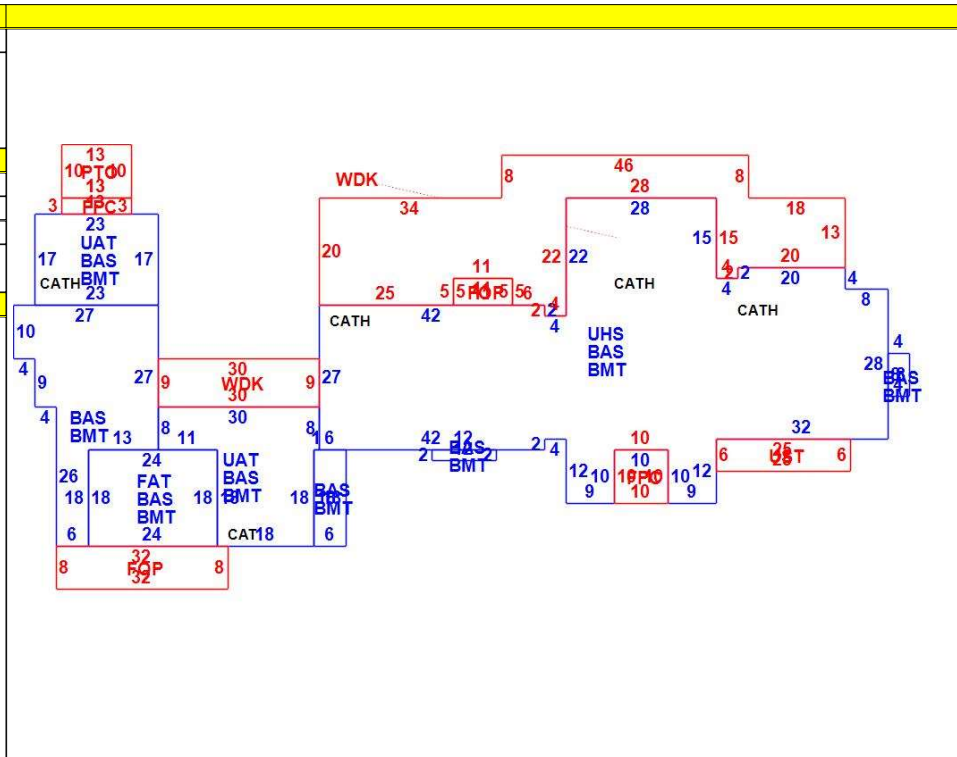

OB - OUTBUILDING & YARD ITEMS(L) / XF - BUILDING EXTRA FEATURES(B)										
Code	Description	L/B	Units	Unit Price	Yr Blt	Cond. Cd	% Gd	Grade	Grade Adj.	Appr. Value
DKHD	Dock-Heavy	L	1	205000.0	1991		44		0.00	90,200
TEN	Tennis Court 7	L	7,200	6.84	1976		4	00	1.00	2,000
BMT	Basement-Unfi	B	5,994	26.01	2015		94		0.00	111,800
FOP	Open Porch-ro	B	311	55.00	2015		94		0.00	11,500
FOPC	Open Prch-roo	B	139	55.00	2015		94		0.00	5,400
FNC5	FENCE-10'CH	L	354	34.35	1976		14		0.00	1,700
FNG1	Gate 4'x3'w	L	2	301.53	1976		4	C	1.00	0
FPL2	Fireplace 1.5 s	B	1	6000.00	2015		94		0.00	5,600
FPO	Ext FP Openin	B	2	2000.00	2015		94		0.00	3,800
WDC	Wood Deck w/	L	1,831	18.00	2015		92		0.00	26,500

BUILDING SUB-AREA SUMMARY SECTION						
Code	Description	Living Area	Floor Area	Eff Area	Unit Cost	Undeprec Value
BAS	First Floor	5,994	5,994	5,994	591.08	3,542,957
BMT	Basement Area	0	5,994	0	0.00	0
FAT	Attic, Finished	65	432	65	88.94	38,420
FOP	Open Porch	0	311	0	0.00	0
FOPC	Open Porch Conc. Floor	0	139	0	0.00	0
PTO	Patio	0	130	0	0.00	0
UAT	Attic, Unfinished	0	955	96	59.42	56,744
UHS	Half Story, Unfinished	0	3,706	1,112	177.36	657,285
UST	Utility Enclosure	0	150	0	0.00	0
WDK	Wood Deck	0	1,831	0	0.00	0
Ttl Gross Liv / Lease Area		6,059	19,642	7,267		4,295,406



CURRENT OWNER		TOPO	UTILITIES	STRT / ROAD	LOCATION	CURRENT ASSESSMENT			
STAVROS, CHRISTOPHER TR 936 SEA VIEW REALTY TRUST 886 MAIN STREET		1 Level	2 Public Water	1 Paved	7 Waterfront	Description	Code	Assessed	Assessed
			4 Gas		1 Excel View	RESIDNTL	1010	5,306,500	5,306,500
			6 Septic		7	RES LAND	1010	8,474,200	8,474,200
SUPPLEMENTAL DATA									
OSTERVILLE MA 02655		Alt Prcl ID		Plan Ref.					
		Split Zonin		Land Ct# 2664-98					
		BID Parcel		#SR					
		ResExpt Q		Life Estate					
		#DL 1 LOT 36 & 186		PP STATU					
		#DL 2		Assoc Pid#					
		GIS ID F_957599_2684776							
						Total		13,780,700	13,780,700

801
 FY2025
 BARNSTABLE, MA

VISION

RECORD OF OWNERSHIP		BK-VOL/PAGE	SALE DATE	Q/U	V/I	SALE PRIC	VC	PREVIOUS ASSESSMENTS (HISTORY)								
								Year	Code	Assessed	Year	Code	Assessed	Year	Code	Assessed
								2025	1010	5,306,500	2024	1010	5,253,200	2023	1010	4,618,400
									1010	8,474,200		1010	8,474,200		1010	7,752,800
								Total		13,780,700	Total		13,727,400	Total		12,371,200

EXEMPTIONS				OTHER ASSESSMENTS			
Year	Code	Description	Amount	Code	Description	Number	Amount
Total							

This signature acknowledges a visit by a Data Collector or Assessor

ASSESSING NEIGHBORHOOD			
Nbhd	Nbhd Name	B	Tracing
WF13			OSTVIL

NOTES			

APPRAISED VALUE SUMMARY	
Appraised Bldg. Value (Card)	4,037,700
Appraised Xf (B) Value (Bldg)	377,700
Appraised Ob (B) Value (Bldg)	891,100
Appraised Land Value (Bldg)	8,474,200
Special Land Value	0
Total Appraised Parcel Value	13,780,700
Valuation Method	C
Total Appraised Parcel Value	13,780,700

BUILDING PERMIT RECORD								VISIT / CHANGE HISTORY						
Permit Id	Issue Date	Type	Description	Amount	Insp Date	% Comp	Date Comp	Comments	Date	Id	Type	Is	Cd	Purpost/Result

LAND LINE VALUATION SECTION																
B	Use Code	Description	Zone	LA	Land Units	Unit Price	Size Adj	AC Disc	Site Index	Cond.	Nbhd.	Nbhd. Adj	Notes	Location Adjustmen	Adj Unit P	Land Value
Total Card Land Units					Parcel Total Land Area					Total Land Value						

CONSTRUCTION DETAIL						CONSTRUCTION DETAIL (CONTINUED)					
Element	Cd	Description				Element	Cd	Description			
Style	06	Conventional									
Model	01	Residential									
Grade:	X+	Exceptional PI									
Stories	1.4										
Exterior Wall 1	14	Wood Shingle				CONDO DATA					
Exterior Wall 2						Parcel Id		C		Owne	0.0
Roof Structure	03	Gable/Hip						B		S	
Roof Cover	01	Metal/Tin				Adjust Type	Code	Description	Factor%		
Interior Wall 1	05	Drywall				Condo Flr					
Interior Wall 2						Condo Unit					
Interior Floor 1	12	Hardwood				COST / MARKET VALUATION					
Interior Floor 2						Building Value New					
Heat Fuel	03	Gas				Year Built					
Heat Type	04	Hot Air				Effective Year Built					
AC Type	03	Central				Depreciation Code					
Bedrooms	04	4 Bedrooms				Remodel Rating					
Full Baths	5					Year Remodeled					
Half Baths	1					Depreciation %					
Extra Fixtures						Functional Obsol					
Total Rooms	7					External Obsol					
Bath Style						Trend Factor					
Kitchen Style						Condition					
Occupancy						Condition %					
Sewer Occupan						Percent Good					
Accessory Apt						RCNLD					
Foundation Alt	01	Poured Conc.				Dep % Ovr					
Rms Prts						Dep Ovr Comment					
Bath Split	51	5 Full-1 Half				Misc Imp Ovr					
						Misc Imp Ovr Comment					
						Cost to Cure Ovr					
						Cost to Cure Ovr Comment					
OB - OUTBUILDING & YARD ITEMS(L) / XF - BUILDING EXTRA FEATURES(B)											
Code	Description	L/B	Units	Unit Price	Yr Blt	Cond. Cd	% Gd	Grade	Grade Adj.	Appr. Value	
UST	Utility Storage-	B	150	17.11	2015		94		0.00	1,700	
BFA3	Bsmt Fin-Exc-	B	3,994	63.36	2015		94		0.00	237,900	
SOL3	Solar PV Pane	B	182	635.00	2015		0		0.00	0	
SPL3	Pool Gunite	L	1,093	75.00	2015		82	00	1.00	63,700	
SPH4	Pool Heater 10	L	1	5454.00	2015		92		0.00	5,000	
JCZ1	Jacuzzi Outsid	L	1	9822.00	2015		92		0.00	9,000	
JCZH	Jacuzzi Heater	L	1	898.00	2015		92		0.00	800	
CBN1	Cabana-Avg	L	588	81.58	2014		80	S	4.25	163,100	
FGRB	Gar Ave w/BM	L	624	80.00	2014		90	X+	2.50	112,300	
GAR4	Det Gar-w/FU	L	624	120.00	2014		90	S	4.25	286,400	
BUILDING SUB-AREA SUMMARY SECTION											
Code	Description	Living Area	Floor Area	Eff Area	Unit Cost	Undeprec Value					
Ttl Gross Liv / Lease Area											

CURRENT OWNER		TOPO	UTILITIES	STRT / ROAD	LOCATION	CURRENT ASSESSMENT			
STAVROS, CHRISTOPHER TR 936 SEA VIEW REALTY TRUST 886 MAIN STREET		1 Level	2 Public Water	1 Paved	7 Waterfront	Description	Code	Assessed	Assessed
			4 Gas		1 Excel View	RESIDNTL	1010	5,306,500	5,306,500
			6 Septic		7	RES LAND	1010	8,474,200	8,474,200
SUPPLEMENTAL DATA									
OSTERVILLE MA 02655		Alt Prcl ID			Plan Ref.				
		Split Zonin			Land Ct# 2664-98				
		BID Parcel			#SR				
		ResExpt Q			Life Estate				
		#DL 1 LOT 36 & 186			PP STATU				
		#DL 2			Assoc Pid#				
		GIS ID F_957599_2684776							
						Total		13,780,700	13,780,700

801
 FY2025
 BARNSTABLE, MA

VISION

RECORD OF OWNERSHIP		BK-VOL/PAGE	SALE DATE	Q/U	V/I	SALE PRIC	VC	PREVIOUS ASSESSMENTS (HISTORY)								
								Year	Code	Assessed	Year	Code	Assessed	Year	Code	Assessed
								2025	1010	5,306,500	2024	1010	5,253,200	2023	1010	4,618,400
									1010	8,474,200		1010	8,474,200		1010	7,752,800
								Total		13,780,700	Total		13,727,400	Total		12,371,200

EXEMPTIONS				OTHER ASSESSMENTS			
Year	Code	Description	Amount	Code	Description	Number	Amount
Total							

This signature acknowledges a visit by a Data Collector or Assessor

ASSESSING NEIGHBORHOOD			
Nbhd	Nbhd Name	B	Tracing
WF13			OSTVIL

NOTES			

APPRAISED VALUE SUMMARY	
Appraised Bldg. Value (Card)	4,037,700
Appraised Xf (B) Value (Bldg)	377,700
Appraised Ob (B) Value (Bldg)	891,100
Appraised Land Value (Bldg)	8,474,200
Special Land Value	0
Total Appraised Parcel Value	13,780,700
Valuation Method	C
Total Appraised Parcel Value	13,780,700

BUILDING PERMIT RECORD							VISIT / CHANGE HISTORY							
Permit Id	Issue Date	Type	Description	Amount	Insp Date	% Comp	Date Comp	Comments	Date	Id	Type	Is	Cd	Purpost/Result

LAND LINE VALUATION SECTION																
B	Use Code	Description	Zone	LA	Land Units	Unit Price	Size Adj	AC Disc	Site Index	Cond.	Nbhd.	Nbhd. Adj	Notes	Location Adjustmen	Adj Unit P	Land Value
Total Card Land Units					Parcel Total Land Area					Total Land Value						

CONSTRUCTION DETAIL						CONSTRUCTION DETAIL (CONTINUED)					
Element	Cd	Description				Element	Cd	Description			
Style	06	Conventional									
Model	01	Residential									
Grade:	X+	Exceptional PI									
Stories	1.4										
Exterior Wall 1	14	Wood Shingle				CONDO DATA					
Exterior Wall 2						Parcel Id		C		Ownr	0.0
Roof Structure	03	Gable/Hip							B		S
Roof Cover	01	Metal/Tin				Adjust Type	Code	Description		Factor%	
Interior Wall 1	05	Drywall				Condo Flr					
Interior Wall 2						Condo Unit					
Interior Floor 1	12	Hardwood				COST / MARKET VALUATION					
Interior Floor 2						Building Value New					
Heat Fuel	03	Gas				Year Built					
Heat Type	04	Hot Air				Effective Year Built					
AC Type	03	Central				Depreciation Code					
Bedrooms	04	4 Bedrooms				Remodel Rating					
Full Baths	5					Year Remodeled					
Half Baths	1					Depreciation %					
Extra Fixtures						Functional Obsol					
Total Rooms	7					External Obsol					
Bath Style						Trend Factor					
Kitchen Style						Condition					
Occupancy						Condition %					
Sewer Occupan						Percent Good					
Accessory Apt						RCNLD					
Foundation Alt	01	Poured Conc.				Dep % Ovr					
Rms Prts						Dep Ovr Comment					
Bath Split	51	5 Full-1 Half				Misc Imp Ovr					
						Misc Imp Ovr Comment					
						Cost to Cure Ovr					
						Cost to Cure Ovr Comment					
OB - OUTBUILDING & YARD ITEMS(L) / XF - BUILDING EXTRA FEATURES(B)											
Code	Description	L/B	Units	Unit Price	Yr Blt	Cond. Cd	% Gd	Grade	Grade Adj.	Appr. Value	
BMT1	Basement-Unfi	L	624	28.00	2014		95		0.00	20,100	
FOPG	Open Prch-rf-c	L	185	49.37	2014		90	X+	2.50	17,100	
GEN	Emergency Ge	L	1	5550.00	1999		60		0.00	3,300	
FPIT	Fire Pit	L	1	3010.00	2015		91	C	1.00	2,700	
PATC	Conc Pavers	L	896	15.46	2015		96		0.00	12,100	
PATC	Conc Pavers	L	130	15.46	2015		96		0.00	2,300	
TUN1	TUNNEL	L	150	500.25	2016		97		0.00	72,800	
BUILDING SUB-AREA SUMMARY SECTION											
Code	Description	Living Area	Floor Area	Eff Area	Unit Cost	Undeprec Value					
Ttl Gross Liv / Lease Area											