

| CURRENT OWNER | | TOPO | UTILITIES | STRT / ROAD | LOCATION | CURRENT ASSESSMENT | | | | 801 FY2025 BARNSTABLE, MA VISION | |
|---|--|----------------|----------------|------------------|----------|--------------------|------|----------|----------|--|---------|
| COHEN, ELAINE R & TREGLIA, ANTH 73 WEBSTER ROAD MARSTONS MIL MA 02648 | | 1 Level | 6 Septic | 1 Paved | | Description | Code | Assessed | Assessed | | |
| | | | 4 Gas | | | RESIDNTL | 1010 | 313,000 | 313,000 | | |
| | | | 2 Public Water | | 6 | RES LAND | 1010 | 186,400 | 186,400 | | |
| SUPPLEMENTAL DATA | | | | | | Total | | | | 499,400 | 499,400 |
| Alt Prcl ID | | Split Zonin | | Plan Ref. 157/97 | | | | | | | |
| BID Parcel | | ResExpt Q YES: | | Land Ct# | | | | | | | |
| #DL 1 LOT 73 | | #DL 2 | | Life Estate | | | | | | | |
| GIS ID F_957549_2709690 | | Assoc Pid# | | | | | | | | | |

| RECORD OF OWNERSHIP | | BK-VOL/PAGE | SALE DATE | Q/U | V/I | SALE PRIC | VC | PREVIOUS ASSESSMENTS (HISTORY) | | | | | | | | | |
|-----------------------------------|--|-------------|-----------|------------|-----|-----------|--------|--------------------------------|---------|------|----------|------|---------|----------|-------|------|----------|
| COHEN, ELAINE R & TREGLIA, ANTHON | | 22270 | 0275 | 08-17-2007 | U | I | 1 | 1A | Year | Code | Assessed | Year | Code | Assessed | Year | Code | Assessed |
| TREGLIA, ANTHONY R | | 4331 | 0151 | 11-15-1984 | U | I | 19,750 | A | 2025 | 1010 | 313,000 | 2024 | 1010 | 311,600 | 2023 | 1010 | 270,400 |
| TREGLIA, ANTHONY R & WILMA R | | 1603 | 0278 | 02-15-1972 | U | | 0 | | | 1010 | 186,400 | | 1010 | 186,400 | | 1010 | 184,200 |
| Total | | | | | | | | | 499,400 | | Total | | 498,000 | | Total | | 454,600 |

| EXEMPTIONS | | | | OTHER ASSESSMENTS | | | | This signature acknowledges a visit by a Data Collector or Assessor | | | | | | | | | | |
|------------|------|-----------------------|--------|-------------------|-------------|--------|--------|---|--|--|--|--|--|--|--|--|--|--|
| Year | Code | Description | Amount | Code | Description | Number | Amount | Comm Int | | | | | | | | | | |
| 2024 | 5C | RESIDENTIAL EXEMPTION | | | | | | | | | | | | | | | | |
| Total | | | 0.00 | | | | | | | | | | | | | | | |

| ASSESSING NEIGHBORHOOD | | | | APPRAISED VALUE SUMMARY | | | | |
|------------------------|-----------|---|---------|-------------------------|--|--|--|--|
| Nbhd | Nbhd Name | B | Tracing | Batch | | | | |
| 0106 | | | MARSTM | | | | | |

| NOTES | | | | | | | | | | APPRAISED VALUE SUMMARY | | | | | | |
|-------|--|--|--|--|--|--|--|--|--|-------------------------------|--|--|--|--|--|---------|
| | | | | | | | | | | Appraised Bldg. Value (Card) | | | | | | 262,400 |
| | | | | | | | | | | Appraised Xf (B) Value (Bldg) | | | | | | 28,700 |
| | | | | | | | | | | Appraised Ob (B) Value (Bldg) | | | | | | 21,900 |
| | | | | | | | | | | Appraised Land Value (Bldg) | | | | | | 186,400 |
| | | | | | | | | | | Special Land Value | | | | | | 0 |
| | | | | | | | | | | Total Appraised Parcel Value | | | | | | 499,400 |
| | | | | | | | | | | Valuation Method | | | | | | C |
| | | | | | | | | | | Total Appraised Parcel Value | | | | | | 499,400 |

| BUILDING PERMIT RECORD | | | | | | | | VISIT / CHANGE HISTORY | | | | | | | |
|------------------------|------------|------|----------------|--------|------------|--------|------------|---|------------|----|------|----|----|----------------------------|--|
| Permit Id | Issue Date | Type | Description | Amount | Insp Date | % Comp | Date Comp | Comments | Date | Id | Type | Is | Cd | Purpost/Result | |
| 17-2072 | 06-30-2017 | 835 | Sid/Wind/Roof/ | 0 | | 100 | | replace windows / doors . slide Air sealing and weatherization | 08-09-2023 | LH | 03 | | 22 | Change of Address | |
| 17-1460 | 05-15-2017 | 822 | Insulation | 2,584 | | 100 | | | 08-04-2023 | EG | 03 | | 16 | In Office Review | |
| 69585 | 06-19-2003 | AD | Addition | 13,520 | 09-09-2003 | 100 | 01-01-2004 | | 05-07-2020 | LS | | | FR | Field Review | |
| | | | | | | | | | 08-26-2019 | CK | 01 | | 03 | Cycl Insp Comp | |
| | | | | | | | | | 07-17-2006 | PT | 02 | | 01 | Meas/Est | |
| | | | | | | | | | 09-09-2003 | MF | 02 | | 02 | Bldg Permit Completed | |
| | | | | | | | | | 05-04-1999 | DD | 01 | | 00 | Meas/Listed-Interior Acces | |

| LAND LINE VALUATION SECTION | | | | | | | | | | | | | | | | | |
|-----------------------------|----------|----------------|------|----|------------|------------|------------------------|---------|------------|-------|-------|-----------|------------------|--------------------|------------|------------|---------|
| B | Use Code | Description | Zone | LA | Land Units | Unit Price | Size Adj | AC Disc | Site Index | Cond. | Nbhd. | Nbhd. Adj | Notes | Location Adjustmen | Adj Unit P | Land Value | |
| 1 | 1010 | Single Fam M-0 | RF | 3 | 0.560 | AC | 176,344.00 | 1.64114 | 1.0000 | 5 | 1.00 | 0106 | 1.150 | | 1.0000 | 332,814.0 | 186,400 |
| Total Card Land Units | | | | | 0.56 | AC | Parcel Total Land Area | | | | | 0.56 | Total Land Value | | | 186,400 | |

| CONSTRUCTION DETAIL | | | CONSTRUCTION DETAIL (CONTINUED) | | |
|---------------------|----|----------------|---------------------------------|----|-------------|
| Element | Cd | Description | Element | Cd | Description |
| Style | 01 | Ranch | | | |
| Model | 01 | Residential | | | |
| Grade: | C | Average | | | |
| Stories | 1 | 1 Story | | | |
| Exterior Wall 1 | 14 | Wood Shingle | | | |
| Exterior Wall 2 | | | | | |
| RooF Structure | 03 | Gable/Hip | | | |
| RooF Cover | 03 | Asph/F Gls/Cmp | | | |
| Interior Wall 1 | 05 | Drywall | | | |
| Interior Wall 2 | | | | | |
| Interior Floor 1 | 12 | Hardwood | | | |
| Interior Floor 2 | | | | | |
| Heat Fuel | 03 | Gas | | | |
| Heat Type | 04 | Hot Air | | | |
| AC Type | 01 | None | | | |
| Bedrooms | 03 | 3 Bedrooms | | | |
| Full Baths | 1 | | | | |
| Half Baths | 1 | | | | |
| Extra Fixtures | | | | | |
| Total Rooms | 6 | 6 Rooms | | | |
| Bath Style | | | | | |
| Kitchen Style | | | | | |
| Occupancy | | | | | |
| Sewer Occupan | | | | | |
| Accessory Apt | | | | | |
| Foundation Alt | 01 | Poured Conc. | | | |
| Rms Prts | | | | | |
| Bath Split | 11 | 1 Full-1 Half | | | |

| CONDO DATA | | | | |
|-------------|------|-------------|---------|-----|
| Parcel Id | | C | Owne | 0.0 |
| Adjust Type | Code | Description | Factor% | |
| Condo Flr | | | | |
| Condo Unit | | | | |

| COST / MARKET VALUATION | |
|--------------------------|---------|
| Building Value New | 349,921 |
| Year Built | 1964 |
| Effective Year Built | 1992 |
| Depreciation Code | A |
| Remodel Rating | |
| Year Remodeled | |
| Depreciation % | 25 |
| Functional Obsol | 0 |
| External Obsol | 0 |
| Trend Factor | 1 |
| Condition | |
| Condition % | |
| Percent Good | 75 |
| RCNLD | 262,400 |
| Dep % Ovr | |
| Dep Ovr Comment | |
| Misc Imp Ovr | |
| Misc Imp Ovr Comment | |
| Cost to Cure Ovr | |
| Cost to Cure Ovr Comment | |

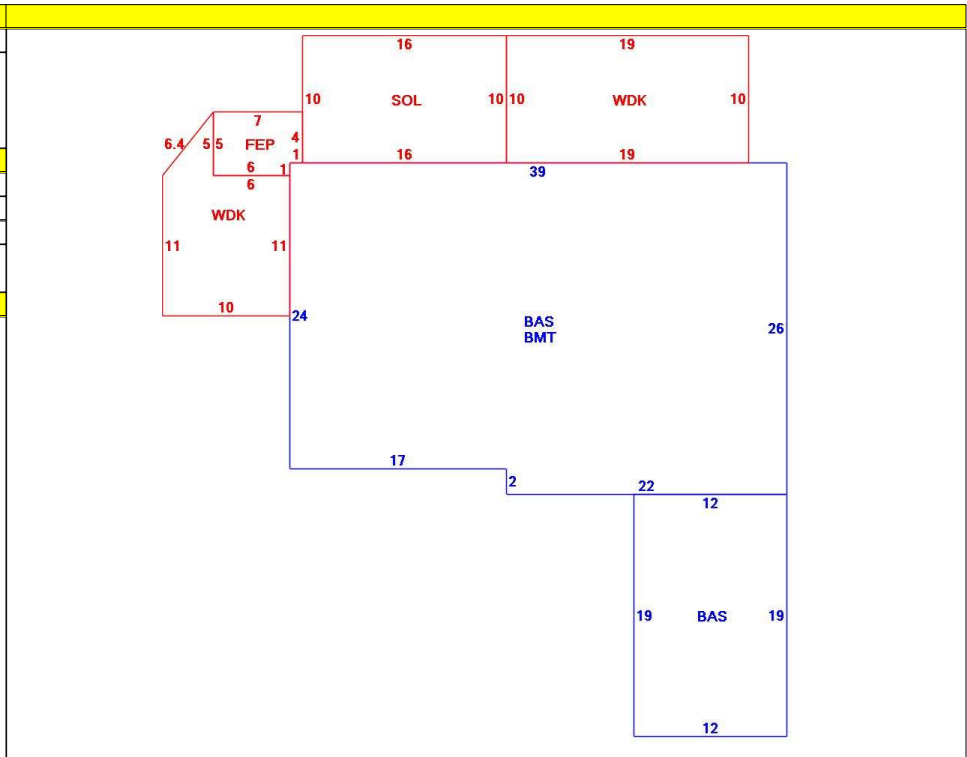

| OB - OUTBUILDING & YARD ITEMS(L) / XF - BUILDING EXTRA FEATURES(B) | | | | | | | | | | |
|--|-----------------|-----|-------|------------|--------|----------|------|-------|------------|-------------|
| Code | Description | L/B | Units | Unit Price | Yr Blt | Cond. Cd | % Gd | Grade | Grade Adj. | Appr. Value |
| FPL1 | Fireplace 1 sto | B | 1 | 5000.00 | 1990 | | 75 | | 0.00 | 3,800 |
| SOL | Solarium | L | 160 | 171.10 | 1994 | | 70 | C | 1.00 | 17,800 |
| WDC | Wood Decking | L | 310 | 20.00 | 1994 | | 50 | | 0.00 | 3,100 |
| FEP | Enclosed porc | B | 34 | 70.00 | 1990 | | 75 | | 0.00 | 3,300 |
| BMT | Basement-Unfi | B | 980 | 26.01 | 1990 | | 75 | | 0.00 | 19,700 |
| SHED | Shed | L | 80 | 18.00 | 2003 | | 68 | | 0.00 | 1,000 |
| FPLG | Gas Fireplace- | B | 1 | 2500.00 | 1990 | | 75 | | 0.00 | 1,900 |

| BUILDING SUB-AREA SUMMARY SECTION | | | | | | |
|-----------------------------------|----------------|-------------|------------|----------|-----------|----------------|
| Code | Description | Living Area | Floor Area | Eff Area | Unit Cost | Undeprec Value |
| BAS | First Floor | 1,208 | 1,208 | 1,208 | 289.67 | 349,921 |
| BMT | Basement Area | 0 | 980 | 0 | 0.00 | 0 |
| FEP | Enclosed Porch | 0 | 34 | 0 | 0.00 | 0 |
| SOL | Solarium | 0 | 160 | 0 | 0.00 | 0 |
| WDC | Wood Deck | 0 | 310 | 0 | 0.00 | 0 |
| Ttl Gross Liv / Lease Area | | 1,208 | 2,692 | 1,208 | | 349,921 |

