

| CURRENT OWNER | | | | TOPO | UTILITIES | STRT / ROAD | LOCATION | CURRENT ASSESSMENT | | | | |
|------------------------------|--|--|--|-------------------------|-----------|------------------|----------|--------------------|------|----------|----------|---------------------------------|
| MCMANUS, MICHAEL J & DONNA M | | | | | | | | Description | Code | Assessed | Assessed | 801 FY2025 BARNSTABLE, MA |
| 318 WILLIMANTIC DRIVE | | | | | | | | RESIDENTL | 1010 | 352,100 | 352,100 | |
| MARSTONS MIL MA 02648 | | | | | | | | RES LAND | 1010 | 179,200 | 179,200 | |
| SUPPLEMENTAL DATA | | | | | | | | Total | | | | |
| Alt Prcl ID | | | | Split Zonin | | Plan Ref. 157/97 | | | | | | VISION |
| BID Parcel | | | | #SR | | Land Ct# | | | | | | |
| ResExpt Q YES: | | | | #DL 1 LOT 28 | | Life Estate | | | | | | |
| #DL 2 | | | | GIS ID F_956394_2709505 | | PP STATU | | | | | | |
| | | | | Assoc Pid# | | | | | | | | |

| RECORD OF OWNERSHIP | | | | BK-VOL/PAGE | SALE DATE | Q/U | V/I | SALE PRIC | VC | PREVIOUS ASSESSMENTS (HISTORY) | | | | | | | |
|----------------------------------|--|--|--|-------------|-----------|------------|-----|-----------|----|--------------------------------|-------|---------|----------|-------|---------|----------|---------|
| MCMANUS, MICHAEL J & DONNA M | | | | 23535 | 0123 | 03-17-2009 | U | I | 1 | 1F | Year | Code | Assessed | Year | Code | Assessed | |
| MCMANUS, MICHAEL J & DONNA M TRS | | | | 16704 | 0167 | 04-07-2003 | U | I | 1 | 1F | 2025 | 1010 | 352,100 | 2024 | 1010 | 328,700 | |
| MCMANUS, MICHAEL J & DONNA M | | | | 16501 | 0066 | 03-04-2003 | U | I | 1 | 1A | | 1010 | 179,200 | 2023 | 1010 | 290,500 | |
| MCMANUS, MICHAEL J & DONNA M TRS | | | | 14106 | 0071 | 08-02-2001 | U | I | 1 | 1A | | | | | | 177,100 | |
| MCMANUS, MICHAEL J & DONNA | | | | 2864 | 0276 | 01-30-1979 | U | | 0 | | Total | | 531,300 | Total | | 507,900 | |
| | | | | | | | | | | Total | | 531,300 | Total | | 507,900 | Total | 467,600 |

| EXEMPTIONS | | | | OTHER ASSESSMENTS | | | |
|------------|------|-----------------------|--------|-------------------|-------------|--------|--------|
| Year | Code | Description | Amount | Code | Description | Number | Amount |
| 2024 | 5C | RESIDENTIAL EXEMPTION | | | | | |
| Total | | | 0.00 | | | | |

| ASSESSING NEIGHBORHOOD | | | |
|------------------------|-----------|---|---------|
| Nbhd | Nbhd Name | B | Tracing |
| 0106 | | | MARSTM |

| NOTES | | | |
|---|--|--|---------|
| This signature acknowledges a visit by a Data Collector or Assessor | | | |
| APPRAISED VALUE SUMMARY | | | |
| Appraised Bldg. Value (Card) | | | 325,000 |
| Appraised Xf (B) Value (Bldg) | | | 22,900 |
| Appraised Ob (B) Value (Bldg) | | | 4,200 |
| Appraised Land Value (Bldg) | | | 179,200 |
| Special Land Value | | | 0 |
| Total Appraised Parcel Value | | | 531,300 |
| Valuation Method | | | C |
| Total Appraised Parcel Value | | | 531,300 |

| BUILDING PERMIT RECORD | | | | | | | | VISIT / CHANGE HISTORY | | | | | | |
|------------------------|------------|------|-------------|--------|------------|--------|------------|------------------------|------------|----|------|----|----|-----------------------|
| Permit Id | Issue Date | Type | Description | Amount | Insp Date | % Comp | Date Comp | Comments | Date | Id | Type | Is | Cd | Purpost/Result |
| 69631 | 06-20-2003 | AD | Addition | 30,000 | 09-09-2003 | 100 | 01-01-2004 | | 07-27-2023 | YB | 03 | | 16 | In Office Review |
| B28260 | 07-02-1985 | AD | Addition | 10,000 | 02-15-1986 | 100 | 12-31-1986 | MM ADD'N | 05-07-2020 | LS | | | FR | Field Review |
| B28260A | 07-01-1985 | AD | Addition | 0 | 01-15-1986 | 100 | 12-31-1986 | MM DORMER | 03-26-2014 | JR | 03 | | 16 | In Office Review |
| B20587 | 09-01-1978 | DW | Dwelling | 0 | 01-15-1979 | 100 | 12-31-1979 | MM 11/2 S | 07-10-2006 | PT | 02 | | 01 | Meas/Est |
| | | | | | | | | | 09-09-2003 | MF | 02 | | 02 | Bldg Permit Completed |

| LAND LINE VALUATION SECTION | | | | | | | | | | | | | | | | |
|-----------------------------|----------|----------------|------|----|------------|------------|------------------------|---------|------------|-------|-------|-----------|------------------|--------------------|------------|------------|
| B | Use Code | Description | Zone | LA | Land Units | Unit Price | Size Adj | AC Disc | Site Index | Cond. | Nbhd. | Nbhd. Adj | Notes | Location Adjustmen | Adj Unit P | Land Value |
| 1 | 1010 | Single Fam M-0 | RF | 3 | 0.460 | AC | 176,344.00 | 1.92125 | 1.0000 | 5 | 1.00 | 0106 | 1.150 | | 1.0000 | 389,614.4 |
| Total Card Land Units | | | | | 0.46 | AC | Parcel Total Land Area | | | | | 0.46 | Total Land Value | | | 179,200 |

| CONSTRUCTION DETAIL | | | CONSTRUCTION DETAIL (CONTINUED) | | |
|--------------------------|------|----------------|---------------------------------|-----|-------------|
| Element | Cd | Description | Element | Cd | Description |
| Style | 04 | Cape Cod | | | |
| Model | 01 | Residential | | | |
| Grade: | C | Average | | | |
| Stories | 1.75 | 1 3/4 Stories | | | |
| Exterior Wall 1 | 14 | Wood Shingle | | | |
| Exterior Wall 2 | 11 | Clapboard | | | |
| RooF Structure | 03 | Gable/Hip | | | |
| RooF Cover | 03 | Asph/F Gls/Cmp | | | |
| Interior Wall 1 | 05 | Drywall | | | |
| Interior Wall 2 | | | | | |
| Interior Floor 1 | 12 | Hardwood | | | |
| Interior Floor 2 | 14 | Carpet | | | |
| Heat Fuel | 04 | Electric | | | |
| Heat Type | 07 | Elec Baseboard | | | |
| AC Type | 01 | None | | | |
| Bedrooms | 04 | 4 Bedrooms | | | |
| Full Baths | 2 | | | | |
| Half Baths | 0 | | | | |
| Extra Fixtures | | | | | |
| Total Rooms | 6 | 6 Rooms | | | |
| Bath Style | | | | | |
| Kitchen Style | | | | | |
| Occupancy | | | | | |
| Sewer Occupan | | | | | |
| Accessory Apt | | | | | |
| Foundation Alt | 01 | Poured Conc. | | | |
| Rms Prts | | | | | |
| Bath Split | 20 | 2 Full-0 Half | | | |
| CONDO DATA | | | COST / MARKET VALUATION | | |
| Parcel Id | | C | Ownr | 0.0 | |
| Adjust Type | Code | Description | Factor% | | |
| Condo Flr | | | | | |
| Condo Unit | | | | | |
| Building Value New | | 401,198 | | | |
| Year Built | | 1978 | | | |
| Effective Year Built | | 1999 | | | |
| Depreciation Code | | A | | | |
| Remodel Rating | | | | | |
| Year Remodeled | | | | | |
| Depreciation % | | 19 | | | |
| Functional Obsol | | 0 | | | |
| External Obsol | | 0 | | | |
| Trend Factor | | 1 | | | |
| Condition | | | | | |
| Condition % | | | | | |
| Percent Good | | 81 | | | |
| RCNLD | | 325,000 | | | |
| Dep % Ovr | | | | | |
| Dep Ovr Comment | | | | | |
| Misc Imp Ovr | | | | | |
| Misc Imp Ovr Comment | | | | | |
| Cost to Cure Ovr | | | | | |
| Cost to Cure Ovr Comment | | | | | |

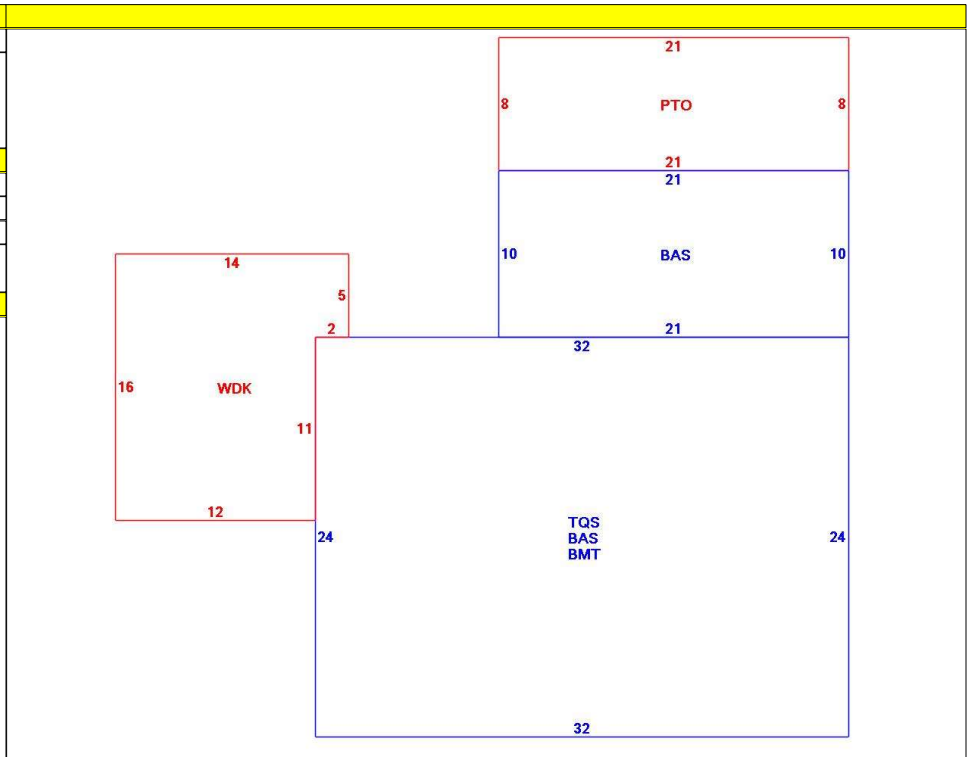

| OB - OUTBUILDING & YARD ITEMS(L) / XF - BUILDING EXTRA FEATURES(B) | | | | | | | | | | |
|--|-----------------|-----|-------|------------|--------|----------|------|-------|------------|-------------|
| Code | Description | L/B | Units | Unit Price | Yr Blt | Cond. Cd | % Gd | Grade | Grade Adj. | Appr. Value |
| FPL2 | Fireplace 1.5 s | B | 1 | 6000.00 | 1997 | | 81 | | 0.00 | 4,900 |
| WDC | Wood Decking | L | 202 | 20.00 | 1997 | | 56 | | 0.00 | 2,700 |
| PAT2 | Patio-Good | L | 168 | 9.94 | 1997 | | 78 | | 0.00 | 1,500 |
| BMT | Basement-Unfi | B | 768 | 26.01 | 1997 | | 81 | | 0.00 | 18,000 |

| BUILDING SUB-AREA SUMMARY SECTION | | | | | | |
|-----------------------------------|---------------------|-------------|------------|----------|-----------|----------------|
| Code | Description | Living Area | Floor Area | Eff Area | Unit Cost | Undeprec Value |
| BAS | First Floor | 978 | 978 | 978 | 271.63 | 265,654 |
| BMT | Basement Area | 0 | 768 | 0 | 0.00 | 0 |
| PTO | Patio | 0 | 168 | 0 | 0.00 | 0 |
| TQS | Three Quarter Story | 499 | 768 | 499 | 176.49 | 135,543 |
| WDK | Wood Deck | 0 | 202 | 0 | 0.00 | 0 |
| Ttl Gross Liv / Lease Area | | 1,477 | 2,884 | 1,477 | | 401,197 |

