

CURRENT OWNER				TOPO	UTILITIES	STRT / ROAD	LOCATION	CURRENT ASSESSMENT				
PAPADELLIS, RANDY C & CATHY A S 16950 SUD CORTILE CT NAPLES FL 34110				1 Level	6 Septic	1 Paved	1 Water View	Description	Code	Assessed	Assessed	801 FY2025 BARNSTABLE, MA VISION
					4 Gas			RESIDENTL	1010	1,518,100	1,518,100	
					2 Public Water		7	RES LAND	1010	1,514,900	1,514,900	
SUPPLEMENTAL DATA								Total				
Alt Prcl ID				Split Zonin		Plan Ref. 189/65						
BID Parcel				ResExpt Q		Land Ct#						
#DL 1				LOTS 1 & 2		#SR						
#DL 2						Life Estate						
GIS ID				F_959064_2689886		PP STATU						
						Assoc Pid#						

RECORD OF OWNERSHIP				BK-VOL/PAGE	SALE DATE	Q/U	V/I	SALE PRIC	VC	PREVIOUS ASSESSMENTS (HISTORY)									
PAPADELLIS, RANDY C & CATHY A SMIT				22823	0131	04-11-2008	U	I	1	1F	Year	Code	Assessed	Year	Code	Assessed V	Year	Code	Assessed
PAPADELLIS, RANDY C & CATHY A SMIT				20284	0091	09-22-2005	Q	I	1,725,000	00	2025	1010	1,518,100	2024	1010	1,555,500	2023	1010	1,334,100
VOLLMANN, HERBERT E & PRISCILLA				14446	0168	11-15-2001	Q	I	625,000	00		1010	1,514,900		1010	1,514,900		1010	1,192,600
MILLER, DAVID W & PAULA L				10678	0146	03-31-1997	Q	I	600,000	00									
LAMPERT, JOAN L				4491	0305	04-16-1985	Q	I	200,000	00									
Total											3,033,000	Total	3,070,400	Total	2,526,700				

EXEMPTIONS				OTHER ASSESSMENTS				This signature acknowledges a visit by a Data Collector or Assessor												
Year	Code	Description	Amount	Code	Description	Number	Amount	Comm Int												
Total			0.00																	

ASSESSING NEIGHBORHOOD				APPRAISED VALUE SUMMARY							
Nbhd	Nbhd Name	B	Tracing	Batch							
0118			OSTVIL								
NOTES											
				Appraised Bldg. Value (Card)				1,339,600			
				Appraised Xf (B) Value (Bldg)				52,700			
				Appraised Ob (B) Value (Bldg)				125,800			
				Appraised Land Value (Bldg)				1,514,900			
				Special Land Value				0			
				Total Appraised Parcel Value				3,033,000			
				Valuation Method				C			
				Total Appraised Parcel Value				3,033,000			

BUILDING PERMIT RECORD										VISIT / CHANGE HISTORY					
Permit Id	Issue Date	Type	Description	Amount	Insp Date	% Comp	Date Comp	Comments		Date	Id	Type	Is	Cd	Purpost/Result
20-1256	05-29-2020	835	Sid/Wind/Roof/	40,000		100		Replace 14 windows around h		04-17-2024	AG	22		22	Change of Address
2015-08789	03-07-2016	804	Addn Alt-Res	190,000	07-05-2016	100	06-30-2017	DEMO EXISTING GARAGE A		05-29-2020	WD			FR	Field Review
2015-08790	02-16-2016	811	Demo - Access	10,000	04-01-2016	100	06-30-2016	DEMO GARAGE		07-26-2016	JR	03		16	In Office Review
201407640	11-06-2014	RW	Repair Work	60,000	01-06-2015	100	06-30-2015	EMERGENCY FOUNDATION		07-19-2016	SR	01		13	CALL BACK
201400208	01-14-2014	RE	Remodel	20,000	09-26-2014	100	06-30-2014	BTH REMOD		07-19-2016	SR	01		13	CALL BACK
201106137	11-17-2011	RE	Remodel	100,000	06-20-2013	100	06-30-2013	KIT REMOD-NW CABINETS,		05-16-2016	JR	03		16	In Office Review
58281	01-09-2002	RA	Remodel-Additi	58,240	06-29-2004	100	01-01-2004			04-01-2016	SR	01		13	CALL BACK

LAND LINE VALUATION SECTION																	
B	Use Code	Description	Zone	LA	Land Units	Unit Price	Size Adj	AC Disc	Site Index	Cond.	Nbhd.	Nbhd. Adj	Notes	Location Adjustmen	Adj Unit P	Land Value	
1	1010	Single Fam M-0	RC	3	0.470	AC	176,344.00	1.88432	1.0000	5	1.00	0117	9.700		1.0000	3,223,215	1,514,900
Total Card Land Units					0.47	AC	Parcel Total Land Area					0.47	Total Land Value				1,514,900

CONSTRUCTION DETAIL			CONSTRUCTION DETAIL (CONTINUED)		
Element	Cd	Description	Element	Cd	Description
Style	06	Conventional			
Model	01	Residential			
Grade:	A+	Luxury Plus			
Stories	3	3 Stories			
Exterior Wall 1	14	Wood Shingle			
Exterior Wall 2					
RooF Structure	03	Gable/Hip			
RooF Cover	03	Asph/F Gls/Cmp			
Interior Wall 1	05	Drywall			
Interior Wall 2					
Interior Floor 1	14	Carpet			
Interior Floor 2	12	Hardwood			
Heat Fuel	03	Gas			
Heat Type	04	Hot Air			
AC Type	03	Central			
Bedrooms	04	4 Bedrooms			
Full Baths	4				
Half Baths	1				
Extra Fixtures					
Total Rooms	10	10 Rooms			
Bath Style					
Kitchen Style					
Occupancy					
Sewer Occupan					
Accessory Apt					
Foundation Alt	02	Conc. Block			
Rms Prts					
Bath Split	41	4 Full-1 Half			
			CONDO DATA		
			Parcel Id	C	Owne 0.0
			Adjust Type Code Description Factor%		
			Condo Flr		
			Condo Unit		
			COST / MARKET VALUATION		
			Building Value New 1,575,943		
			Year Built 1890		
			Effective Year Built 2005		
			Depreciation Code E		
			Remodel Rating 04		
			Year Remodeled 2002		
			Depreciation % 15		
			Functional Obsol 0		
			External Obsol 0		
			Trend Factor 1		
			Condition		
			Condition %		
			Percent Good 85		
			RCNLD 1,339,600		
			Dep % Ovr		
			Dep Ovr Comment		
			Misc Imp Ovr		
			Misc Imp Ovr Comment		
			Cost to Cure Ovr		
			Cost to Cure Ovr Comment		

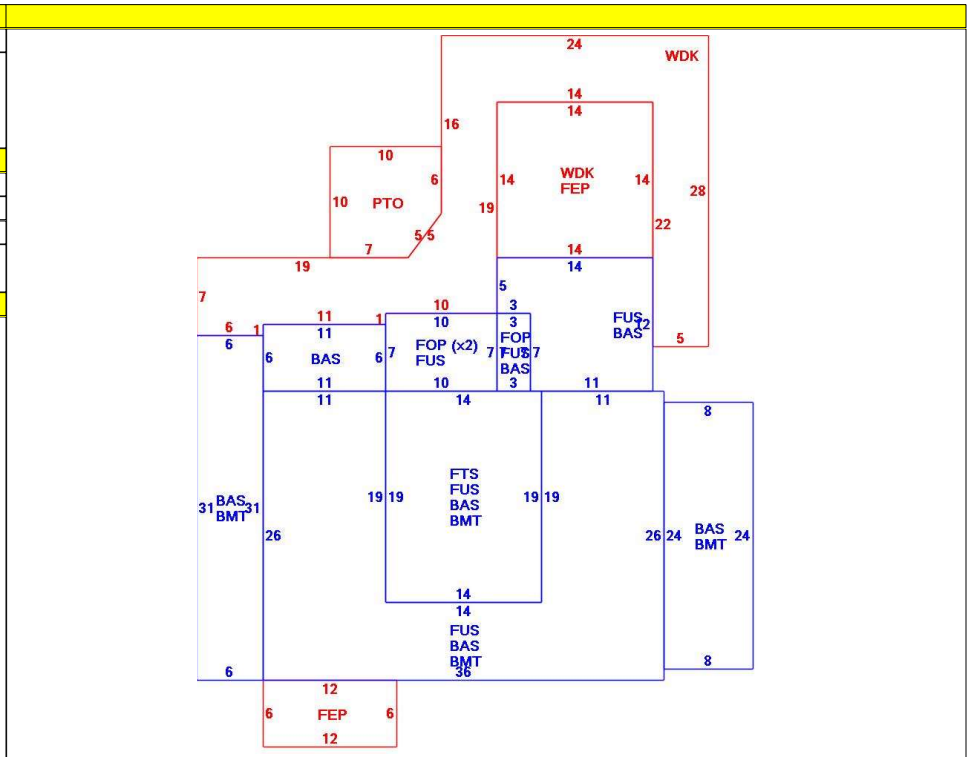

OB - OUTBUILDING & YARD ITEMS(L) / XF - BUILDING EXTRA FEATURES(B)										
Code	Description	L/B	Units	Unit Price	Yr Blt	Cond. Cd	% Gd	Grade	Grade Adj.	Appr. Value
BFA	Bsmt Fin-Avg	B	400	17.36	2005		85		0.00	5,900
WDC	Wood Decking	L	196	20.00	2001		64		0.00	3,000
FOP	Open Porch-ro	B	161	55.00	2005		85		0.00	6,600
FEP	Enclosed porc	B	268	70.00	2005		85		0.00	12,900
BMT	Basement-Unfi	B	1,314	26.01	2005		85		0.00	27,300
WDC	Wood Deck w/	L	488	18.00	2001		64		0.00	5,300
PAT2	Patio-Good	L	94	9.94	2008		89		0.00	1,000
GEN	Emergency Ge	L	1	5550.00	2014		90		0.00	5,000
GAR4	Det Gar-w/FU	L	440	120.00	2015		91	X	2.32	111,500

BUILDING SUB-AREA SUMMARY SECTION						
Code	Description	Living Area	Floor Area	Eff Area	Unit Cost	Undeprec Value
BAS	First Floor	1,548	1,548	1,548	527.42	816,452
BMT	Basement Area	0	1,314	0	0.00	0
FEP	Enclosed Porch	0	268	0	0.00	0
FOP	Open Porch	0	161	0	0.00	0
FTS	Finished Third Story	266	266	266	527.42	140,295
FUS	Upper Story	1,174	1,174	1,174	527.42	619,196
PTO	Patio	0	94	0	0.00	0
WDK	Wood Deck	0	684	0	0.00	0
Ttl Gross Liv / Lease Area		2,988	5,509	2,988		1,575,943

