

CURRENT OWNER		TOPO	UTILITIES	STRT / ROAD	LOCATION	CURRENT ASSESSMENT				
PERRY, LYNNE D						Description	Code	Assessed	Assessed	801 FY2025 BARNSTABLE, MA
344 OST-WEST BARNSTABLE RD						RESIDNTL	1010	473,500	473,500	
OSTERVILLE MA 02655					6	RES LAND	1010	195,400	195,400	
SUPPLEMENTAL DATA										
Alt Prcl ID				Plan Ref. 266/9						
Split Zonin				Land Ct#						
BID Parcel				#SR						
ResExpt Q YES:				Life Estate						
#DL 1 LOT 2				PP STATU						
#DL 2										
GIS ID F_958947_2700052				Assoc Pid#						
							Total	668,900	668,900	

VISION

RECORD OF OWNERSHIP		BK-VOL/PAGE	SALE DATE	Q/U	V/I	SALE PRIC	VC	PREVIOUS ASSESSMENTS (HISTORY)					
PERRY, LYNNE D		10865 0342	07-24-1997	U	V	0		Year	Code	Assessed	Year	Code	Assessed
PERRY, LYNNE D		97P0285 0	02-20-1997	U	I	0	1A	2025	1010	473,500	2024	1010	449,000
MONIZ, MANUEL H & LENA R		2520 0280	06-02-1977	U		0			1010	195,400	2023	1010	398,200
												1010	193,100
							Total	668,900	Total	644,400	Total	591,300	

EXEMPTIONS			OTHER ASSESSMENTS					
Year	Code	Description	Amount	Code	Description	Number	Amount	Comm Int
2016	5C	RESIDENTIAL EXEMPTION						
Total			0.00					

This signature acknowledges a visit by a Data Collector or Assessor

ASSESSING NEIGHBORHOOD				APPRAISED VALUE SUMMARY		
Nbhd	Nbhd Name	B	Tracing	Batch		
0106				MARSTM		
NOTES					Appraised Bldg. Value (Card)	426,900
					Appraised Xf (B) Value (Bldg)	42,800
					Appraised Ob (B) Value (Bldg)	3,800
					Appraised Land Value (Bldg)	195,400
					Special Land Value	0
					Total Appraised Parcel Value	668,900
					Valuation Method	C
					Total Appraised Parcel Value	668,900

BUILDING PERMIT RECORD								VISIT / CHANGE HISTORY						
Permit Id	Issue Date	Type	Description	Amount	Insp Date	% Comp	Date Comp	Comments	Date	Id	Type	Is	Cd	Purpost/Result
18-3319	10-09-2018	822	Insulation	4,000	06-30-2019	100	06-30-2019	Add 50 sq ft of R-30 fiberglass,	05-27-2020	LS			FR	Field Review
61774	06-13-2002	WD	Wood Deck	2,300	11-25-2002	100	01-01-2003		02-18-2020	SR	02		03	Cycl Insp Comp
31392	06-05-1998	AD	Addition	25,000	12-28-1998	100	01-01-1999		06-02-2015	TW	03		16	In Office Review
									09-16-2014	JR	03		16	In Office Review
									01-03-2007	PT	02		14	Cyclical Inspection
									11-25-2002	MF	02		02	Bldg Permit Completed
									05-18-2000	MF	02		02	Bldg Permit Completed

LAND LINE VALUATION SECTION																
B	Use Code	Description	Zone	LA	Land Units	Unit Price	Size Adj	AC Disc	Site Index	Cond.	Nbhd.	Nbhd. Adj	Notes	Location Adjustmen	Adj Unit P	Land Value
1	1010	Single Fam M-0	RF	3	0.700 AC	176,344.00	1.37675	1.0000	5	1.00	0106	1.150		1.0000	279,205.4	195,400
Total Card Land Units					0.70	AC	Parcel Total Land Area					0.70	Total Land Value			195,400

CONSTRUCTION DETAIL			CONSTRUCTION DETAIL (CONTINUED)		
Element	Cd	Description	Element	Cd	Description
Style	04	Cape Cod			
Model	01	Residential			
Grade:	C	Average			
Stories	1.75	1 3/4 Stories			
Exterior Wall 1	25	Vinyl Siding			
Exterior Wall 2					
Roof Structure	03	Gable/Hip			
Roof Cover	03	Asph/F Gls/Cmp			
Interior Wall 1	05	Drywall			
Interior Wall 2					
Interior Floor 1	14	Carpet			
Interior Floor 2	12	Hardwood			
Heat Fuel	03	Gas			
Heat Type	05	Hot Water			
AC Type	01	None			
Bedrooms	04	4 Bedrooms			
Full Baths	3				
Half Baths	0				
Extra Fixtures					
Total Rooms	7	7 Rooms			
Bath Style					
Kitchen Style	02	Modernized			
Occupancy					
Sewer Occupan					
Accessory Apt					
Foundation Alt	02	Conc. Block			
Rms Prts					
Bath Split	30	3 Full-0 Half			

CONDO DATA				
Parcel Id	C	Owne	0.0	
Adjust Type	Code	Description	Factor%	
Condo Flr	Condo Unit			

COST / MARKET VALUATION		
Building Value New		609,848
Year Built		1952
Effective Year Built		1986
Depreciation Code		A
Remodel Rating		
Year Remodeled		
Depreciation %		30
Functional Obsol		0
External Obsol		0
Trend Factor		1
Condition		
Condition %		
Percent Good		70
RCNLD		426,900
Dep % Ovr		
Dep Ovr Comment		
Misc Imp Ovr		
Misc Imp Ovr Comment		
Cost to Cure Ovr		
Cost to Cure Ovr Comment		

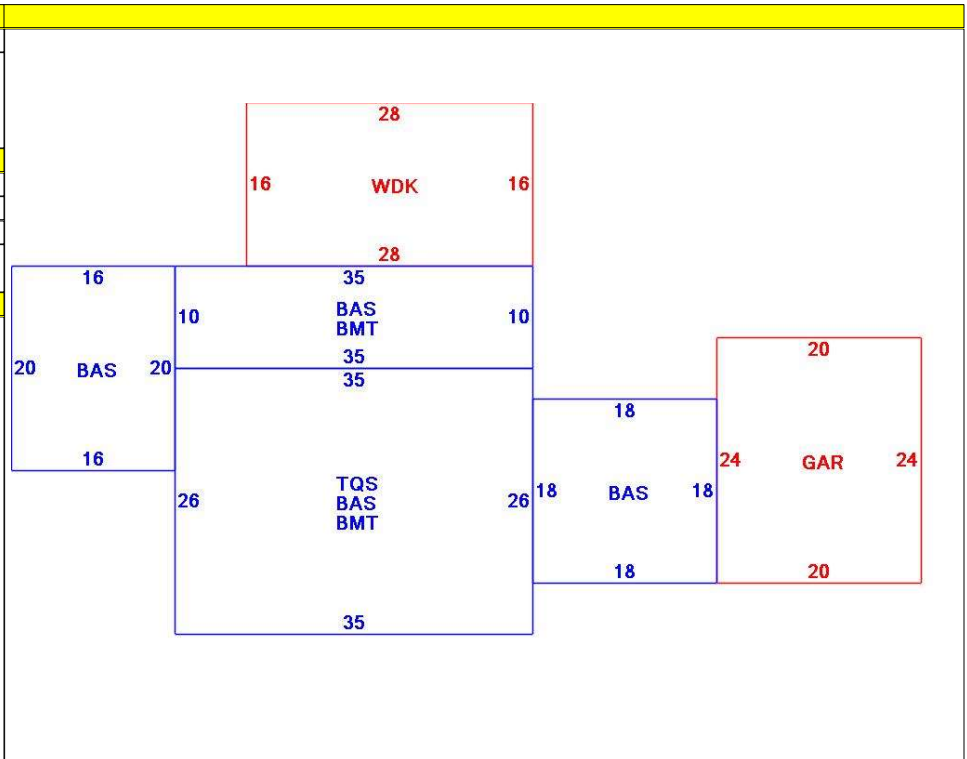

OB - OUTBUILDING & YARD ITEMS(L) / XF - BUILDING EXTRA FEATURES(B)										
Code	Description	L/B	Units	Unit Price	Yr Blt	Cond. Cd	% Gd	Grade	Grade Adj.	Appr. Value
FPL2	Fireplace 1.5 s	B	2	6000.00	1984		70		0.00	8,400
WDC	Wood Decking	L	448	20.00	1991		44		0.00	3,800
GAR	Attached Gara	B	480	40.00	1984		70		0.00	12,600
BMT	Basement-Unfi	B	1,260	26.01	1984		70		0.00	21,800

BUILDING SUB-AREA SUMMARY SECTION						
Code	Description	Living Area	Floor Area	Eff Area	Unit Cost	Undeprec Value
BAS	First Floor	1,904	1,904	1,904	244.33	465,204
BMT	Basement Area	0	1,260	0	0.00	0
GAR	Attached Garage	0	480	0	0.00	0
TQS	Three Quarter Story	592	910	592	158.95	144,643
WDK	Wood Deck	0	448	0	0.00	0
Ttl Gross Liv / Lease Area		2,496	5,002	2,496		609,847

