

| CURRENT OWNER  |  | TOPO    | UTILITIES      | STRT / ROAD  | LOCATION     | CURRENT ASSESSMENT |      |           |           | 801<br>FY2025<br>BARNSTABLE, MA<br><br><b>VISION</b> |           |
|--|--|---------|----------------|--|--------------|--------------------|------|-----------|-----------|--|-----------|
| BURKE, JOSEPH H<br><br>242 SEA VIEW AVENUE<br><br>OSTERVILLE MA 02655                                    |  | 1 Level | 2 Public Water | 1 Paved  | 1 Water View | Description        | Code | Assessed  | Assessed  |  |           |
|  |  |         | 4 Gas          |  |              | RESIDNTL           | 1010 | 824,200   | 824,200   |  |           |
|  |  |         | 6 Septic       |  | 7            | RES LAND           | 1010 | 2,078,800 | 2,078,800 |  |           |
| <b>SUPPLEMENTAL DATA</b>   |  |         |                |  |              | Total              |      |           |           | 2,903,000  | 2,903,000 |
| Alt Prcl ID<br>Split Zonin<br>BID Parcel<br>ResExpt Q INFO:<br>#DL 1<br>#DL 2<br>GIS ID F_963757_2686531 |  |         |                | Plan Ref. 27/113<br>Land Ct#<br>#SR<br>Life Estate<br>PP STATU<br>Assoc Pid# |              |                    |      |           |           |  |           |

| RECORD OF OWNERSHIP         |  | BK-VOL/PAGE | SALE DATE | Q/U        | V/I | SALE PRIC | VC | PREVIOUS ASSESSMENTS (HISTORY) |           |       |           |           |       |           |           |      |           |
|-----------------------------|--|-------------|-----------|------------|-----|-----------|----|--------------------------------|-----------|-------|-----------|-----------|-------|-----------|-----------|------|-----------|
| BURKE, JOSEPH H             |  | 24160       | 0179      | 11-13-2009 | U   | I         | 0  | 1                              | Year      | Code  | Assessed  | Year      | Code  | Assessed  | Year      | Code | Assessed  |
| BURKE, JOSEPH H             |  | 23472       | 0202      | 02-24-2009 | U   | I         | 1  | 1F                             | 2025      | 1010  | 824,200   | 2024      | 1010  | 778,200   | 2023      | 1010 | 663,100   |
| BURKE, JOSEPH H & F WILLIAM |  | 23112       | 0302      | 08-21-2008 | U   | I         | 1  | 1                              |           | 1010  | 2,078,800 |           | 1010  | 2,078,800 |           | 1010 | 2,677,300 |
| BURKE, HOPE M ESTATE OF     |  | 03P1344     | 0         | 03-04-2005 | U   | I         | 0  | 1                              |           |       |           |           |       |           |           |      |           |
| BURKE, HOPE M               |  | 2587        | 0052      | 09-26-1977 | U   | I         | 0  | 1                              |           |       |           |           |       |           |           |      |           |
| Total                       |  |             |           |            |     |           |    |                                | 2,903,000 | Total |           | 2,857,000 | Total |           | 3,340,400 |      |           |

| EXEMPTIONS |      |                          |        | OTHER ASSESSMENTS |             |        |        | This signature acknowledges a visit by a Data Collector or Assessor |  |  |  |  |  |  |  |  |  |  |
|------------|------|--------------------------|--------|-------------------|-------------|--------|--------|---|--|--|--|--|--|--|--|--|--|--|
| Year       | Code | Description              | Amount | Code              | Description | Number | Amount | Comm Int  |  |  |  |  |  |  |  |  |  |  |
| 2024       | N5C  | NO RESIDENTIAL EXEMPTION |        |                   |             |        |        |   |  |  |  |  |  |  |  |  |  |  |
| Total      |      |                          | 0.00   |                   |             |        |        |   |  |  |  |  |  |  |  |  |  |  |

| ASSESSING NEIGHBORHOOD |           |   |         | APPRAISED VALUE SUMMARY |  |  |  |
|------------------------|-----------|---|---------|-------------------------|--|--|--|
| Nbhd                   | Nbhd Name | B | Tracing | Batch                   |  |  |  |
| 0119                   |           |   | OSTVIL  |                         |  |  |  |

| NOTES |  |  |  |  |  |  |  |  |  | APPRAISED VALUE SUMMARY       |  |  |  |  |  |           |
|-------|--|--|--|--|--|--|--|--|--|-------------------------------|--|--|--|--|--|-----------|
|       |  |  |  |  |  |  |  |  |  | Appraised Bldg. Value (Card)  |  |  |  |  |  | 759,500   |
|       |  |  |  |  |  |  |  |  |  | Appraised Xf (B) Value (Bldg) |  |  |  |  |  | 43,100    |
|       |  |  |  |  |  |  |  |  |  | Appraised Ob (B) Value (Bldg) |  |  |  |  |  | 21,600    |
|       |  |  |  |  |  |  |  |  |  | Appraised Land Value (Bldg)   |  |  |  |  |  | 2,078,800 |
|       |  |  |  |  |  |  |  |  |  | Special Land Value            |  |  |  |  |  | 0         |
|       |  |  |  |  |  |  |  |  |  | Total Appraised Parcel Value  |  |  |  |  |  | 2,903,000 |
|       |  |  |  |  |  |  |  |  |  | Valuation Method              |  |  |  |  |  | C         |
|       |  |  |  |  |  |  |  |  |  | Total Appraised Parcel Value  |  |  |  |  |  | 2,903,000 |

| BUILDING PERMIT RECORD |            |      |                |        |            |        |            |                               |  | VISIT / CHANGE HISTORY |    |      |    |    |                       |
|------------------------|------------|------|----------------|--------|------------|--------|------------|-------------------------------|--|------------------------|----|------|----|----|-----------------------|
| Permit Id              | Issue Date | Type | Description    | Amount | Insp Date  | % Comp | Date Comp  | Comments                      |  | Date                   | Id | Type | Is | Cd | Purpost/Result        |
| EXPR-24-7              | 06-03-2024 | 835  |                | 16,000 |            | 0      |            | Strip and re-roof approximate |  | 06-03-2020             | WD |      |    | FR | Field Review          |
| 18-2457                | 08-01-2018 | 835  | Sid/Wind/Roof/ | 15,000 |            | 100    |            | reside                        |  | 05-24-2018             | KM | 02   |    | 03 | Cycl Insp Comp        |
| 16-655                 | 03-17-2016 | 835  | Sid/Wind/Roof/ | 2,500  |            | 0      |            | re-roof stripping old         |  | 02-07-2014             | JR | 03   |    | 15 | Abatement Review      |
| 200804512              | 09-09-2008 | AD   | Addition       | 29,000 | 12-09-2008 | 100    | 06-30-2009 | WIDOWS WALK                   |  | 02-05-2010             | DR | 22   |    | 22 | Change of Address     |
| 61440                  | 05-30-2002 | AD   | Addition       | 38,400 | 04-10-2003 | 100    | 01-01-2003 |                               |  | 07-29-2009             | NF | 03   |    | 52 | New Construction      |
| 61106                  | 05-14-2002 | SP   | Swimming Pool  | 16,500 | 04-10-2003 | 100    | 01-01-2003 |                               |  | 12-09-2008             | MK | 02   |    | 02 | Bldg Permit Completed |
|                        |            |      |                |        |            |        |            |                               |  | 03-29-2007             | PT | 02   |    | 14 | Cyclical Inspection   |

| LAND LINE VALUATION SECTION |          |                |      |    |            |            |                        |         |            |       |       |           |                  |                    |            |            |           |
|-----------------------------|----------|----------------|------|----|------------|------------|------------------------|---------|------------|-------|-------|-----------|------------------|--------------------|------------|------------|-----------|
| B                           | Use Code | Description    | Zone | LA | Land Units | Unit Price | Size Adj               | AC Disc | Site Index | Cond. | Nbhd. | Nbhd. Adj | Notes            | Location Adjustmen | Adj Unit P | Land Value |           |
| 1                           | 1010     | Single Fam M-0 | RF-1 | 3  | 0.810      | AC         | 176,344.00             | 1.21279 | 1.0000     | 5     | 1.00  | 0119      | 12.000           |                    | 1.0000     | 2,566,422  | 2,078,800 |
| Total Card Land Units       |          |                |      |    | 0.81       | AC         | Parcel Total Land Area |         |            |       |       | 0.81      | Total Land Value |                    |            | 2,078,800  |           |

| CONSTRUCTION DETAIL |    |                | CONSTRUCTION DETAIL (CONTINUED) |    |             |
|---------------------|----|----------------|---------------------------------|----|-------------|
| Element             | Cd | Description    | Element                         | Cd | Description |
| Style               | 03 | Colonial       |                                 |    |             |
| Model               | 01 | Residential    |                                 |    |             |
| Grade:              | C+ | Average Plus   |                                 |    |             |
| Stories             | 2  | 2 Stories      |                                 |    |             |
| Exterior Wall 1     | 25 | Vinyl Siding   |                                 |    |             |
| Exterior Wall 2     |    |                |                                 |    |             |
| Roof Structure      | 03 | Gable/Hip      |                                 |    |             |
| Roof Cover          | 03 | Asph/F Gls/Cmp |                                 |    |             |
| Interior Wall 1     | 03 | Plastered      |                                 |    |             |
| Interior Wall 2     |    |                |                                 |    |             |
| Interior Floor 1    | 14 | Carpet         |                                 |    |             |
| Interior Floor 2    | 12 | Hardwood       |                                 |    |             |
| Heat Fuel           | 03 | Gas            |                                 |    |             |
| Heat Type           | 05 | Hot Water      |                                 |    |             |
| AC Type             | 01 | None           |                                 |    |             |
| Bedrooms            | 04 | 4 Bedrooms     |                                 |    |             |
| Full Baths          | 3  |                |                                 |    |             |
| Half Baths          | 0  |                |                                 |    |             |
| Extra Fixtures      |    |                |                                 |    |             |
| Total Rooms         | 10 | 10 Rooms       |                                 |    |             |
| Bath Style          |    |                |                                 |    |             |
| Kitchen Style       |    |                |                                 |    |             |
| Occupancy           |    |                |                                 |    |             |
| Sewer Occupan       |    |                |                                 |    |             |
| Accessory Apt       |    |                |                                 |    |             |
| Foundation Alt      | 01 | Poured Conc.   |                                 |    |             |
| Rms Prts            |    |                |                                 |    |             |
| Bath Split          | 30 | 3 Full-0 Half  |                                 |    |             |

| CONDO DATA  |      |             |         |          |
|-------------|------|-------------|---------|----------|
| Parcel Id   |      | C           |         | Ownr 0.0 |
| Adjust Type | Code | Description | Factor% |          |
| Condo Flr   |      |             |         |          |
| Condo Unit  |      |             |         |          |

| COST / MARKET VALUATION  |         |
|--------------------------|---------|
| Building Value New       | 915,070 |
| Year Built               | 1984    |
| Effective Year Built     | 2002    |
| Depreciation Code        | A       |
| Remodel Rating           |         |
| Year Remodeled           |         |
| Depreciation %           | 17      |
| Functional Obsol         | 0       |
| External Obsol           | 0       |
| Trend Factor             | 1       |
| Condition                |         |
| Condition %              |         |
| Percent Good             | 83      |
| RCNLD                    | 759,500 |
| Dep % Ovr                |         |
| Dep Ovr Comment          |         |
| Misc Imp Ovr             |         |
| Misc Imp Ovr Comment     |         |
| Cost to Cure Ovr         |         |
| Cost to Cure Ovr Comment |         |

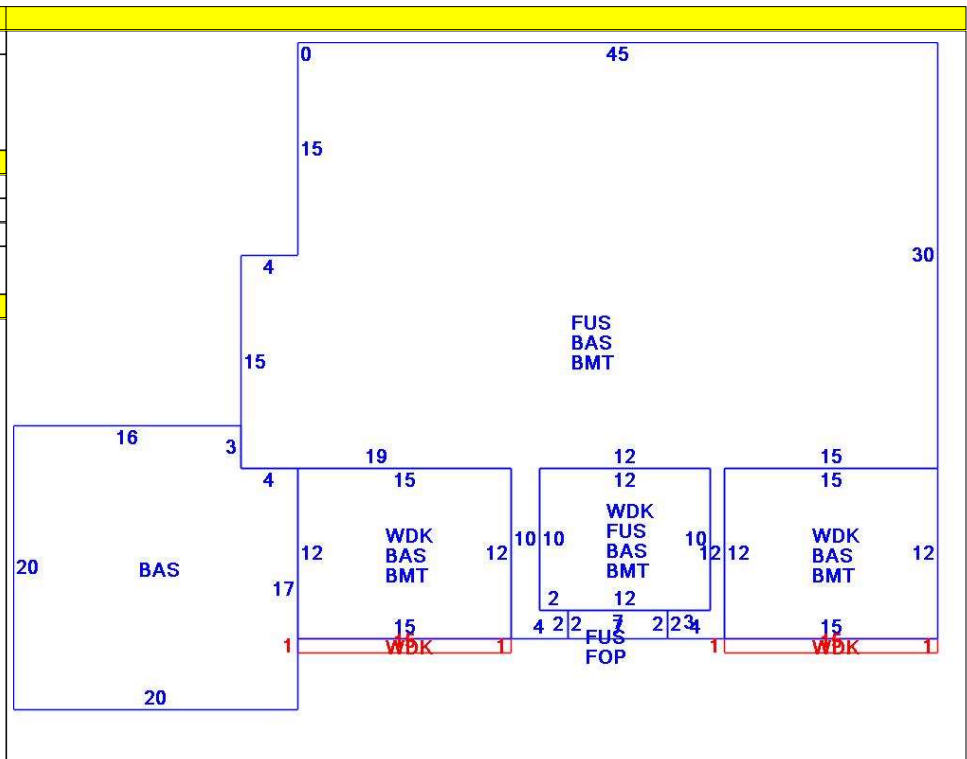

| OB - OUTBUILDING & YARD ITEMS(L) / XF - BUILDING EXTRA FEATURES(B) |                 |     |       |            |        |          |      |       |            |             |
|--|-----------------|-----|-------|------------|--------|----------|------|-------|------------|-------------|
| Code   | Description     | L/B | Units | Unit Price | Yr Blt | Cond. Cd | % Gd | Grade | Grade Adj. | Appr. Value |
| FPL3   | Fireplace 2 sto | B   | 1     | 7000.00    | 2000   |          | 83   |       | 0.00       | 5,800       |
| SPL2   | Pool Vinyl      | L   | 288   | 55.00      | 2002   |          | 56   | 00    | 1.00       | 10,300      |
| WDC  | Wood Decking    | L   | 510   | 20.00      | 1999   |          | 60   |       | 0.00       | 5,700       |
| FOP  | Open Porch-ro   | B   | 14    | 55.00      | 2000   |          | 83   |       | 0.00       | 1,100       |
| BMT  | Basement-Unfi   | B   | 1,936 | 26.01      | 2000   |          | 83   |       | 0.00       | 36,200      |
| SPH1   | Pool Heater <   | L   | 1     | 2434.00    | 2017   |          | 96   |       | 0.00       | 2,300       |
| PAT1   | Patio- Average  | L   | 392   | 5.89       | 2002   |          | 83   |       | 0.00       | 1,900       |
| SHED   | Shed            | L   | 80    | 18.00      | 2017   |          | 96   |       | 0.00       | 1,400       |

| BUILDING SUB-AREA SUMMARY SECTION |               |             |            |          |           |                |
|-----------------------------------|---------------|-------------|------------|----------|-----------|----------------|
| Code                              | Description   | Living Area | Floor Area | Eff Area | Unit Cost | Undeprec Value |
| BAS                               | First Floor   | 2,324       | 2,324      | 2,324    | 233.79    | 543,337        |
| BMT                               | Basement Area | 0           | 1,936      | 0        | 0.00      | 0              |
| FOP                               | Open Porch    | 0           | 14         | 0        | 0.00      | 0              |
| FUS                               | Upper Story   | 1,590       | 1,590      | 1,590    | 233.79    | 371,732        |
| WDK                               | Wood Deck     | 0           | 510        | 0        | 0.00      | 0              |
| Ttl Gross Liv / Lease Area        |               | 3,914       | 6,374      | 3,914    |           | 915,069        |

