

CURRENT OWNER				TOPO	UTILITIES	STRT / ROAD	LOCATION	CURRENT ASSESSMENT					
SISCOE, JASON D								Description	Code	Assessed	Assessed	801 FY2025 BARNSTABLE, MA	
27 TRUDY LN							2	RESIDNTL	1010	604,100	604,100		
COTUIT MA 02635				SUPPLEMENTAL DATA					RES LAND	1010	246,900	246,900	VISION
Alt Prcl ID Split Zonin BID Parcel ResExpt Q YES: #DL 1 LOT 9 #DL 2 GIS ID F_944745_2688594				Plan Ref. 284/98 Land Ct# #SR Life Estate PP STATU Assoc Pid#									
								Total		851,000	851,000		

RECORD OF OWNERSHIP				BK-VOL/PAGE	SALE DATE	Q/U	V/I	SALE PRIC	VC	PREVIOUS ASSESSMENTS (HISTORY)								
SISCOE, JASON D				15492 0156	08-20-2002	U	V	165,000	1P	Year	Code	Assessed	Year	Code	Assessed	Year	Code	Assessed
LEWIS, M LEONARD & ANN MARIE TRS				5055 0015	05-15-1986	U	V	1	A	2025	1010	604,100	2024	1010	597,600	2023	1010	508,500
LEWIS, M LEONARD & ANN MARIE				3303 0241	06-12-1981	U		0			1010	246,900		1010	246,900		1010	224,400
								Total		851,000	Total		844,500	Total		732,900		

EXEMPTIONS				OTHER ASSESSMENTS				
Year	Code	Description	Amount	Code	Description	Number	Amount	Comm Int
2024	5C	RESIDENTIAL EXEMPTION	0.00					
Total			0.00					

ASSESSING NEIGHBORHOOD			
Nbhd	Nbhd Name	B	Tracing
0107			COTUIT

NOTES			
This signature acknowledges a visit by a Data Collector or Assessor			
APPRAISED VALUE SUMMARY			
Appraised Bldg. Value (Card)			528,000
Appraised Xf (B) Value (Bldg)			62,600
Appraised Ob (B) Value (Bldg)			13,500
Appraised Land Value (Bldg)			246,900
Special Land Value			0
Total Appraised Parcel Value			851,000
Valuation Method			C
Total Appraised Parcel Value			851,000

BUILDING PERMIT RECORD								VISIT / CHANGE HISTORY						
Permit Id	Issue Date	Type	Description	Amount	Insp Date	% Comp	Date Comp	Comments	Date	Id	Type	Is	Cd	Purpost/Result
63626	09-25-2002	DW	Dwelling	172,800	02-28-2003	100	01-01-2004		07-26-2023	JO	03		16	In Office Review
									10-18-2022	SR	02		03	Cycl Insp Comp
									05-26-2020	WD			FR	Field Review
									08-21-2013	RB	03		03	Cycl Insp Comp

LAND LINE VALUATION SECTION																	
B	Use Code	Description	Zone	LA	Land Units	Unit Price	Size Adj	AC Disc	Site Index	Cond.	Nbhd.	Nbhd. Adj	Notes	Location Adjustmen	Adj Unit P	Land Value	
1	1010	Single Fam M-0	RF	2	1.000 AC	176,344.00	1.00000	1.0000	5	1.00	0107	1.400		1.0000	246,881.6	246,900	
Total Card Land Units					1.00	AC	Parcel Total Land Area					1.00	Total Land Value			246,900	

CONSTRUCTION DETAIL			CONSTRUCTION DETAIL (CONTINUED)		
Element	Cd	Description	Element	Cd	Description
Style	01	Ranch			
Model	01	Residential			
Grade:	C+	Average Plus			
Stories	1	1 Story			
Exterior Wall 1	14	Wood Shingle			
Exterior Wall 2	11	Clapboard			
RooF Structure	03	Gable/Hip			
RooF Cover	03	Asph/F Gls/Cmp			
Interior Wall 1	03	Plastered			
Interior Wall 2					
Interior Floor 1	12	Hardwood			
Interior Floor 2	14	Carpet			
Heat Fuel	03	Gas			
Heat Type	05	Hot Water			
AC Type	03	Central			
Bedrooms	03	3 Bedrooms			
Full Baths	2				
Half Baths	1				
Extra Fixtures					
Total Rooms	7	7 Rooms			
Bath Style					
Kitchen Style					
Occupancy					
Sewer Occupan					
Accessory Apt					
Foundation Alt	01	Poured Conc.			
Rms Prts					
Bath Split	21	2 Full-1 Half			
CONDO DATA			COST / MARKET VALUATION		
Parcel Id		C	Owne	0.0	
Adjust Type	Code	Description	Factor%		
Condo Flr					
Condo Unit					
Building Value New			561,654		
Year Built		2002			
Effective Year Built		2016			
Depreciation Code		G			
Remodel Rating					
Year Remodeled					
Depreciation %		6			
Functional Obsol		0			
External Obsol		0			
Trend Factor		1			
Condition					
Condition %					
Percent Good		94			
RCNLD		528,000			
Dep % Ovr					
Dep Ovr Comment					
Misc Imp Ovr					
Misc Imp Ovr Comment					
Cost to Cure Ovr					
Cost to Cure Ovr Comment					

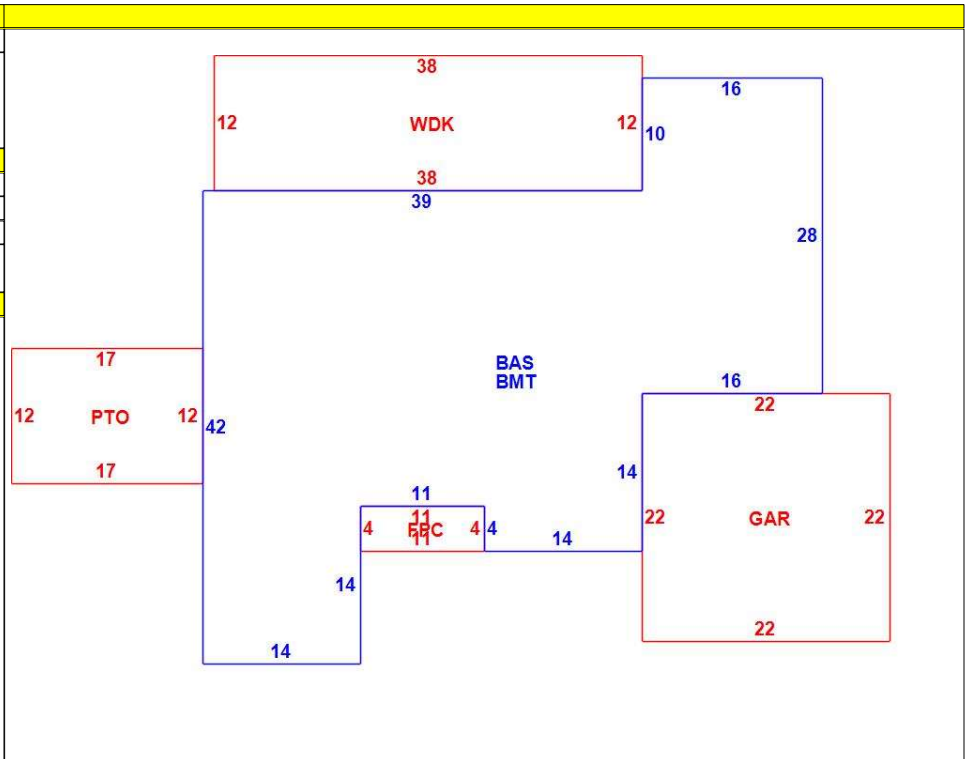

OB - OUTBUILDING & YARD ITEMS(L) / XF - BUILDING EXTRA FEATURES(B)										
Code	Description	L/B	Units	Unit Price	Yr Blt	Cond. Cd	% Gd	Grade	Grade Adj.	Appr. Value
WDC	Wood Decking	L	456	20.00	2006		74		0.00	6,400
FOPC	Open Prch-roo	B	44	55.00	2014		94		0.00	2,500
GAR	Attached Gara	B	484	40.00	2014		94		0.00	17,100
BMT	Basement-Unfi	B	1,792	26.01	2014		94		0.00	38,300
PATF	Flagstone Pav	L	204	30.00	2006		87		0.00	5,800
FPL1	Fireplace 1 sto	B	1	5000.00			94		0.00	4,700
SHED	Shed	L	96	18.00	2013		78		0.00	1,300

BUILDING SUB-AREA SUMMARY SECTION						
Code	Description	Living Area	Floor Area	Eff Area	Unit Cost	Undeprec Value
BAS	First Floor	1,792	1,792	1,792	313.42	561,654
BMT	Basement Area	0	1,792	0	0.00	0
FPC	Open Porch Conc. Floor	0	44	0	0.00	0
GAR	Attached Garage	0	484	0	0.00	0
PTO	Patio	0	204	0	0.00	0
WDC	Wood Deck	0	456	0	0.00	0
Ttl Gross Liv / Lease Area		1,792	4,772	1,792		561,654

